

# Medical Imaging; Evolution of Understanding

by *Gerrit Muller* Buskerud University College

e-mail: `gerrit.muller@embeddedsystems.nl`

`www.gaudisite.nl`

## Abstract

The medical imaging workstation is used as case to show the increased understanding during the creation of the product. We also show the later strategic vision based on the increased customer understanding.

### Distribution

This article or presentation is written as part of the Gaudí project. The Gaudí project philosophy is to improve by obtaining frequent feedback. Frequent feedback is pursued by an open creation process. This document is published as intermediate or nearly mature version to get feedback. Further distribution is allowed as long as the document remains complete and unchanged.

February 10, 2011  
status: preliminary  
draft  
version: 0

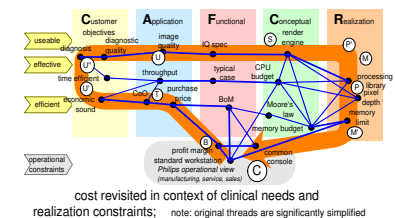

# Easyvision serving three URF examination rooms

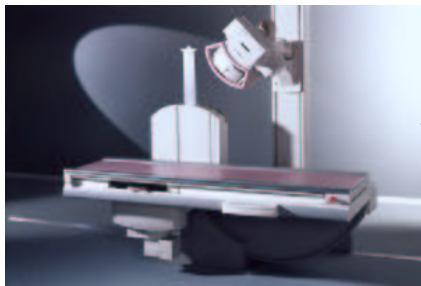
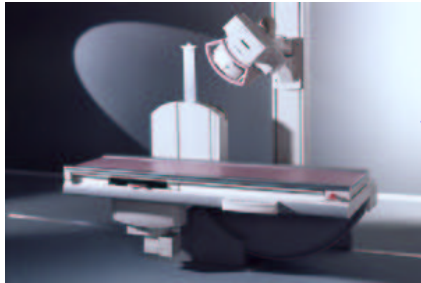
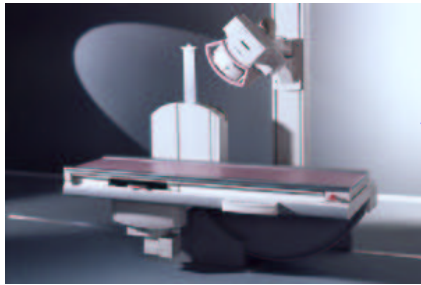

URF-systems



EasyVision: Medical Imaging Workstation

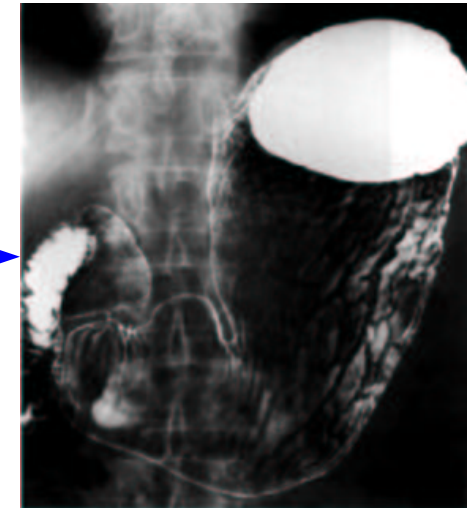

typical clinical image (intestines)

# X-ray rooms from examination to reading around 1990

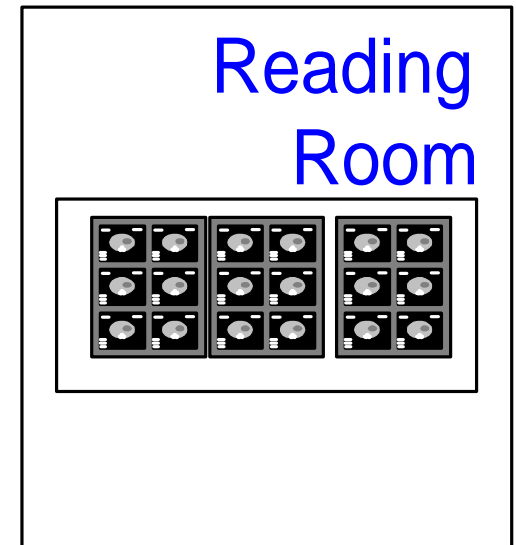
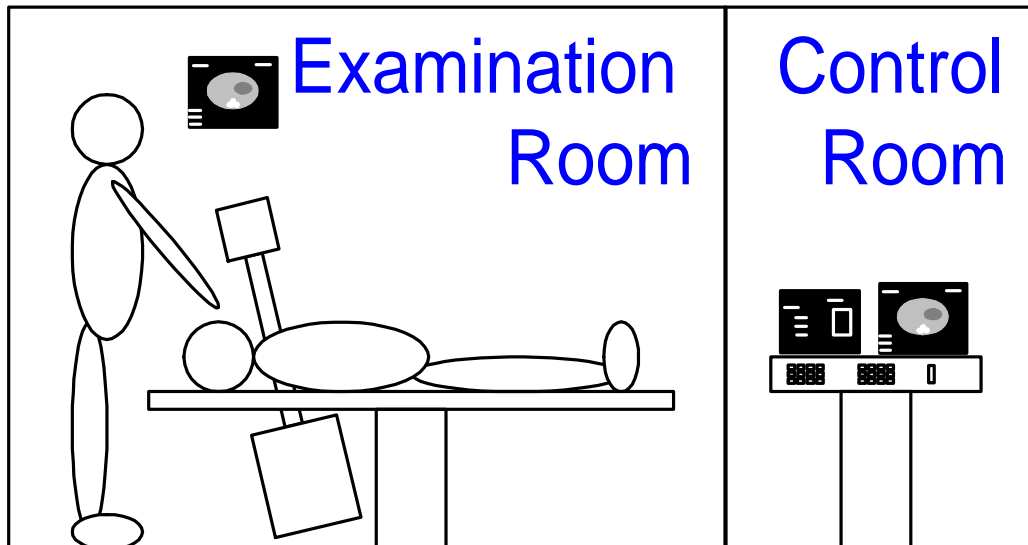
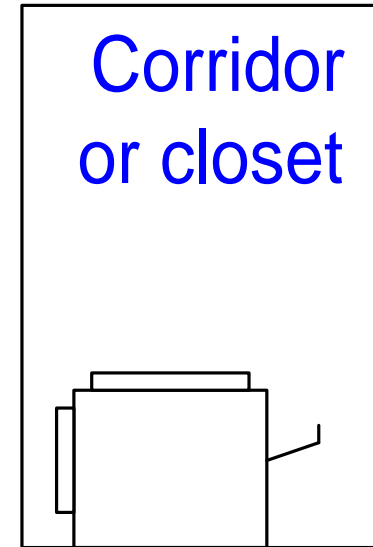
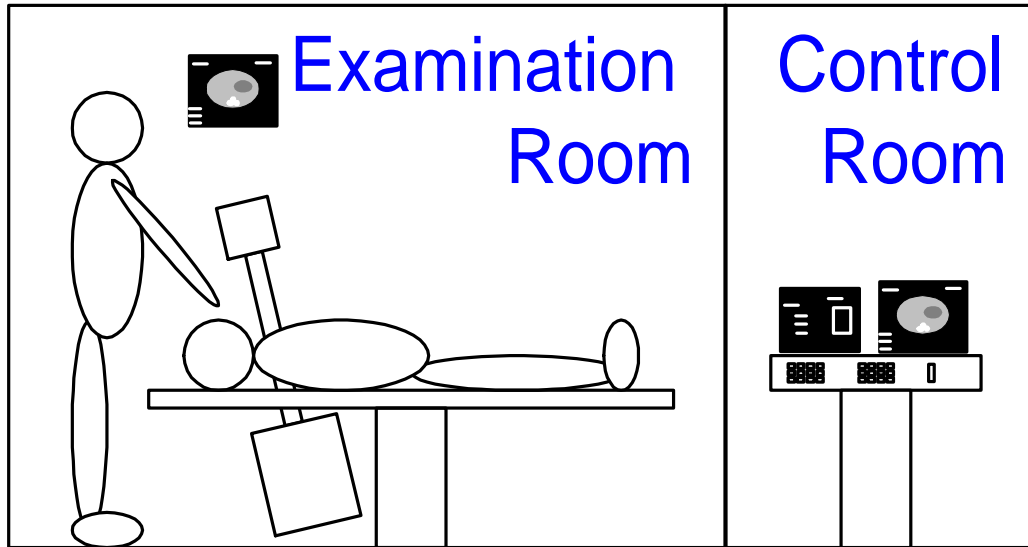

# X-ray rooms with Easyvision applied as printserver

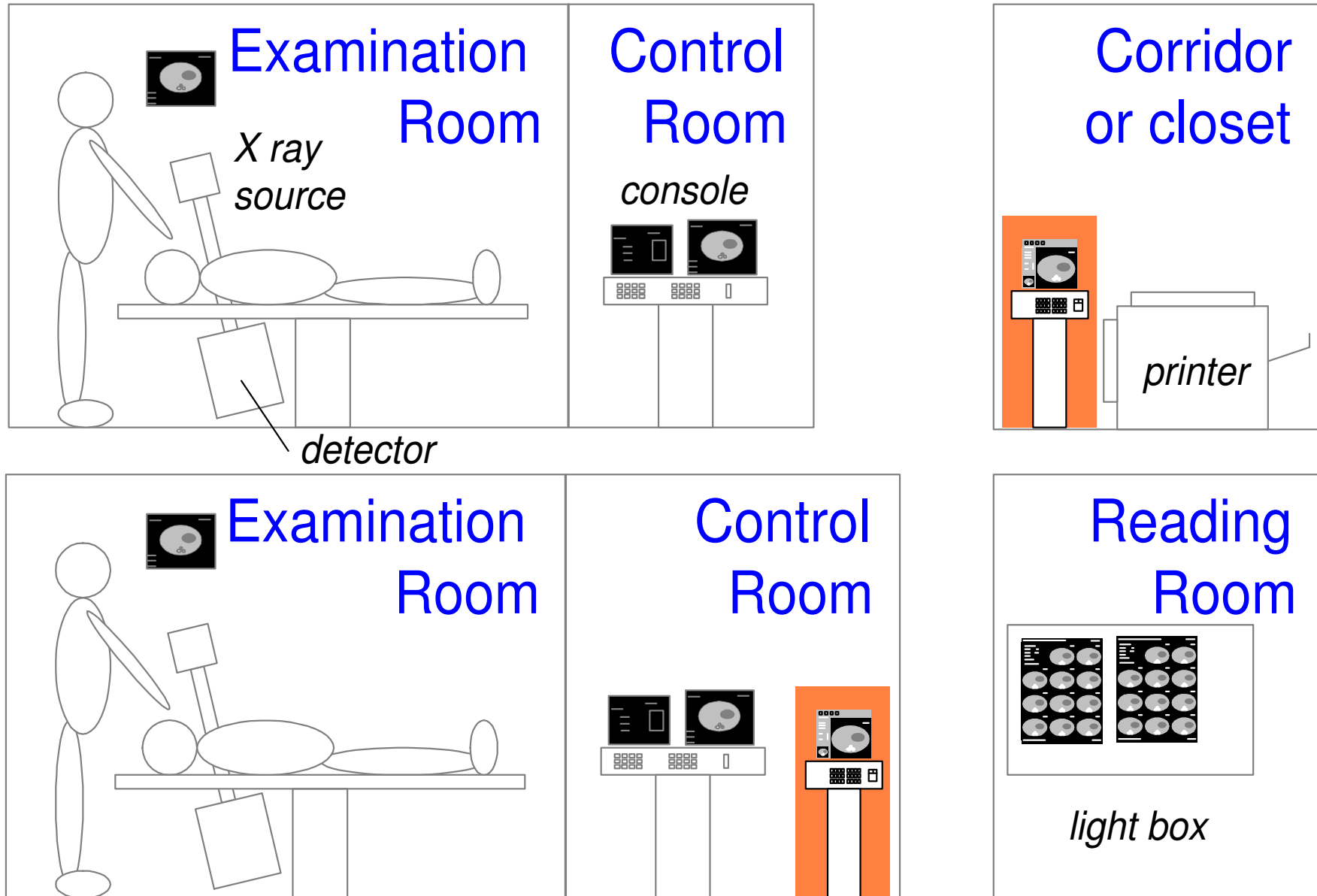

# Comparison screen copy versus optimized film

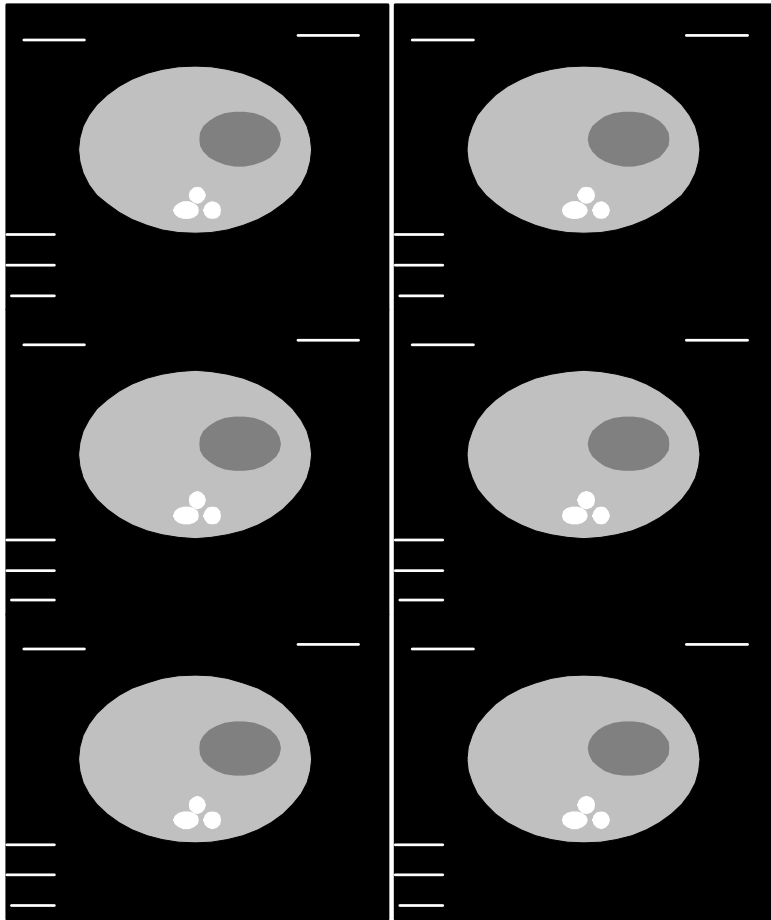

old: screen copy

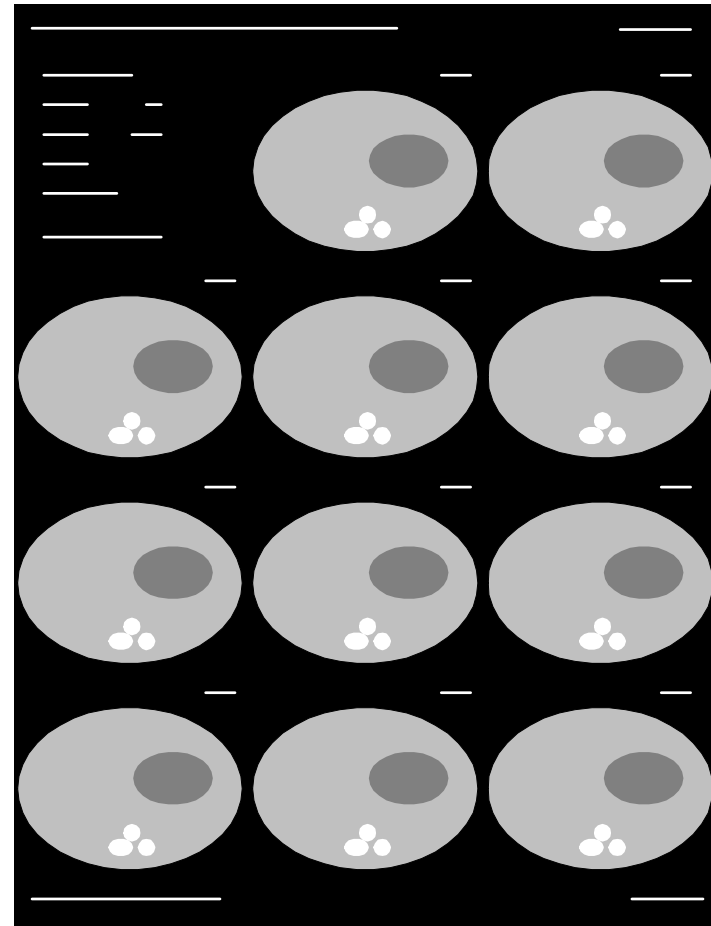

new: SW formatting

20 to 50% less film needed

# CAFCR viewpoints

---

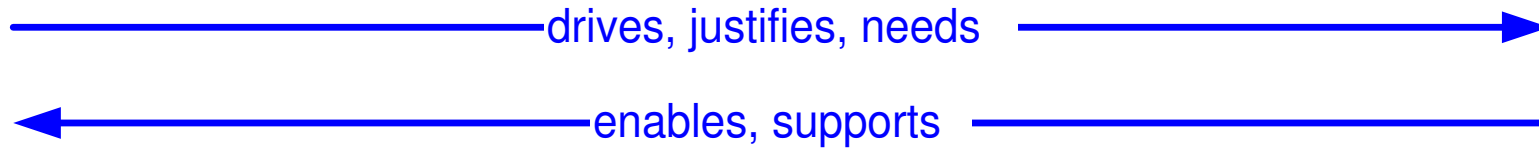

**What** does Customer need  
in Product and **Why?**

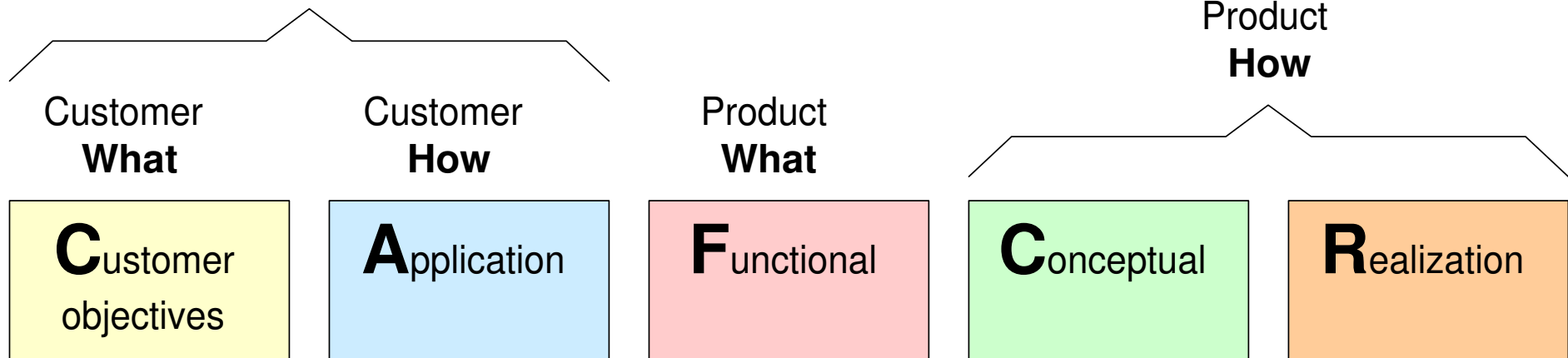

# Time line of Viewing Products

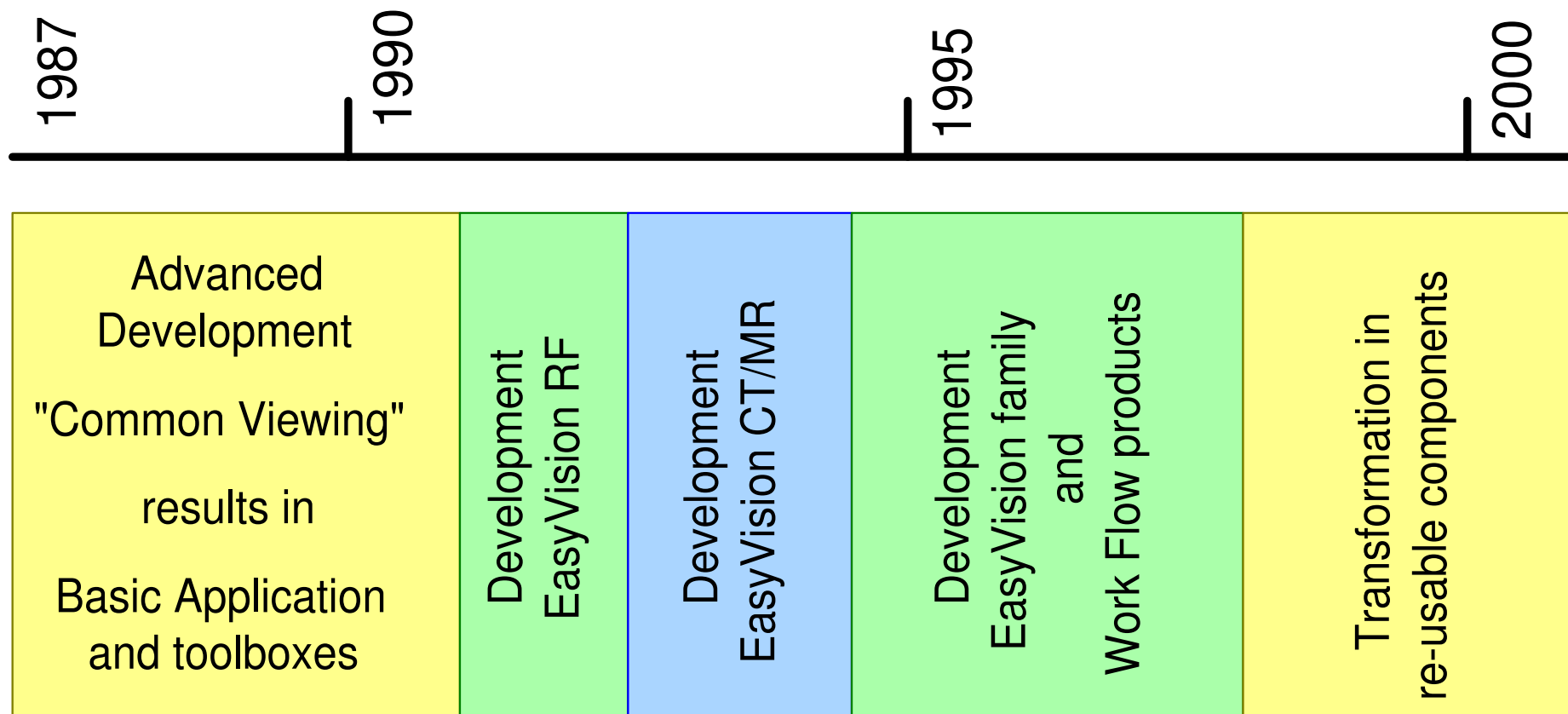

# Chronology of Easyvision RF R1 development

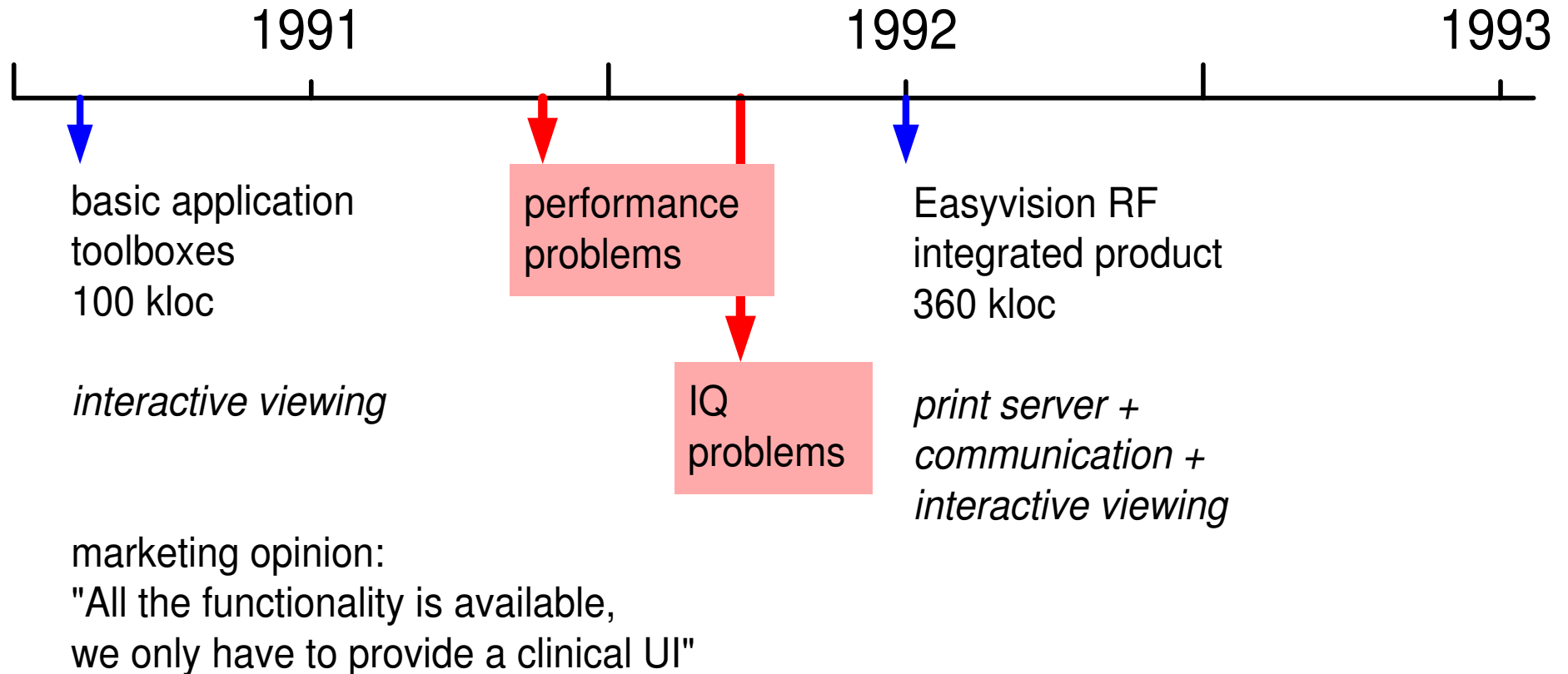

# Technology Innovations initiated by AD

---

performance  
cost



- standard UNIX based workstation
- full SW implementation, more flexible
- object oriented design and implementation (Objective-C)
- graphical User Interface, with windows, mouse etcetera
- call back scheduling, fine-grained notification
- data base engine, fast, reliable and robust
- extensive set of toolboxes
- property based configuration
- multiple coordinate spaces

# Challenges for product creation

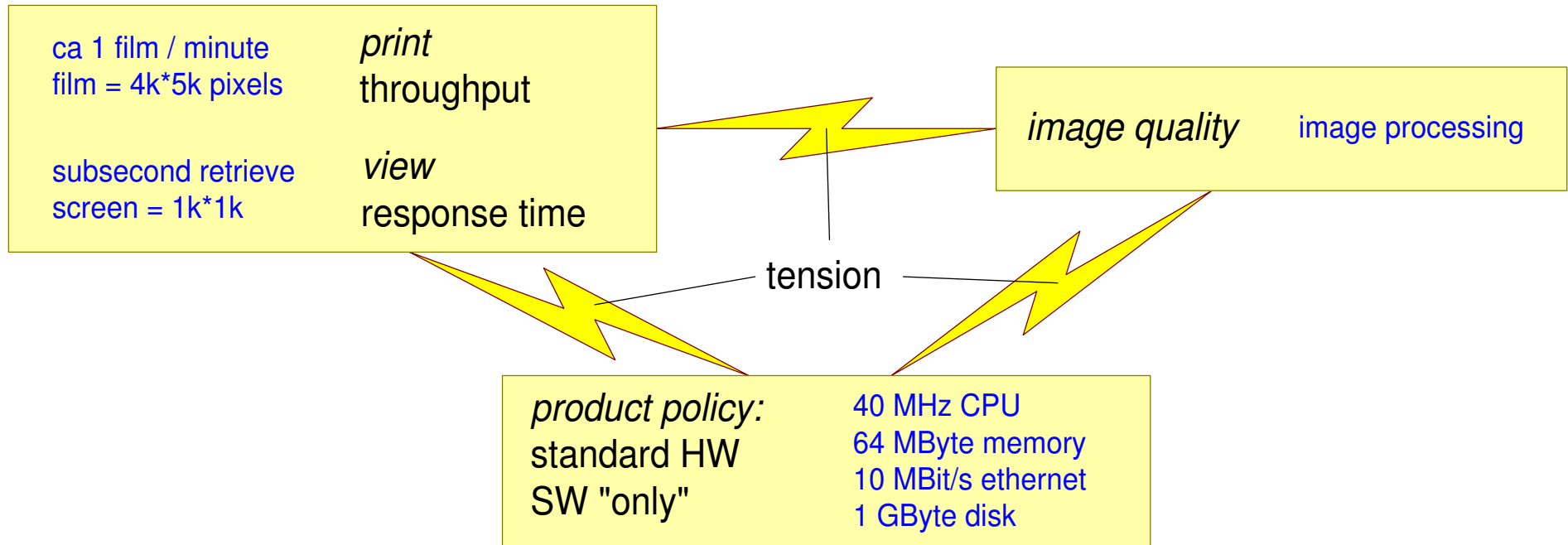

# Top level decomposition

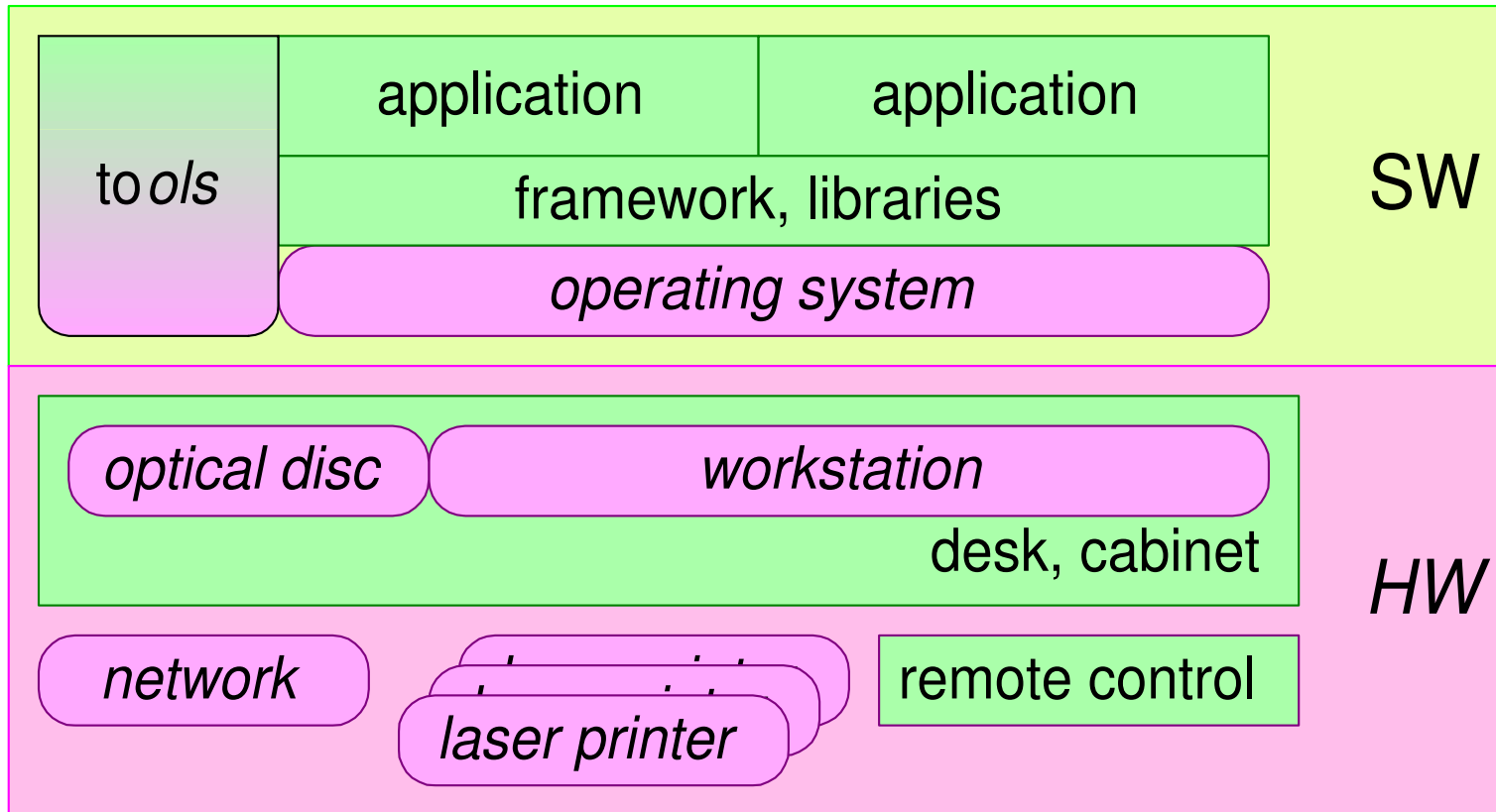

# Thread of reasoning; introvert phase

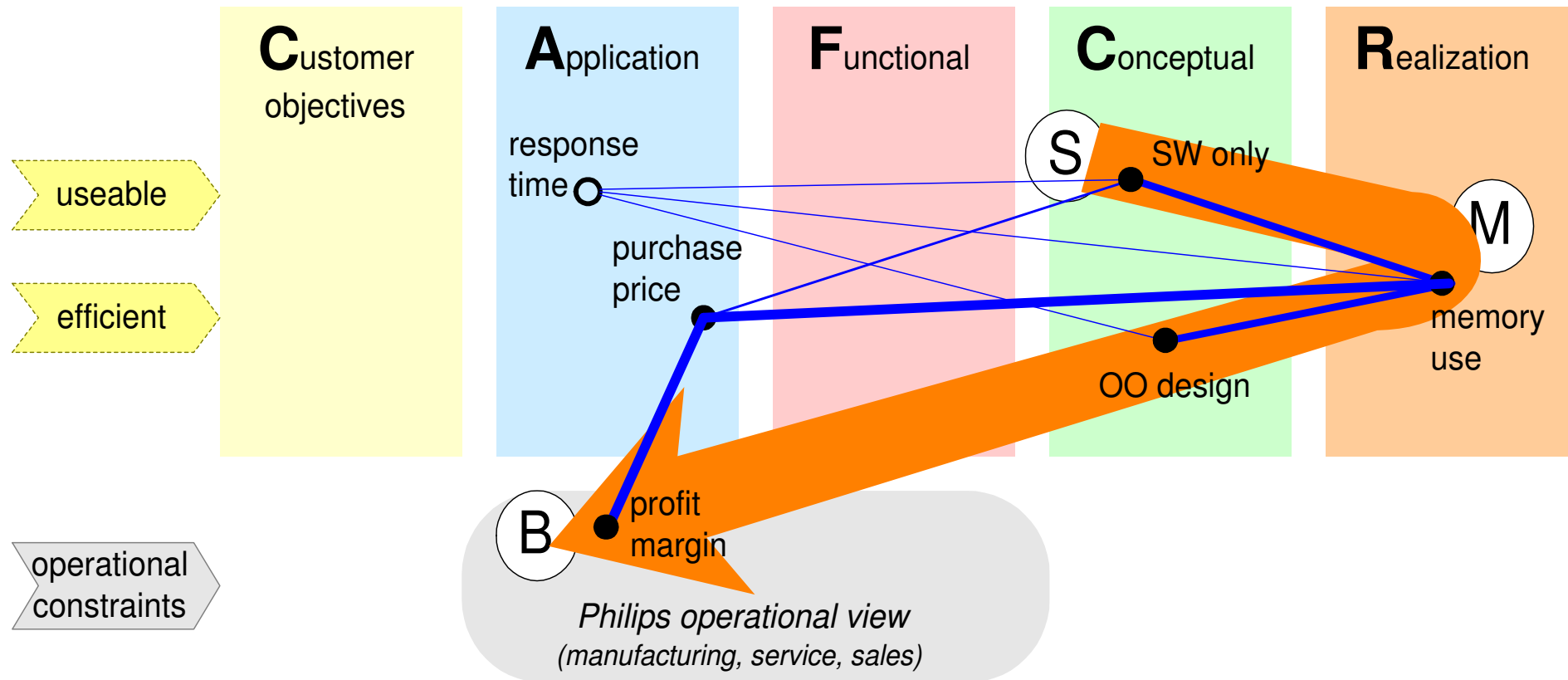

Introvert view: cost and impact of new technologies

# Memory usage half way R1

total measured memory usage

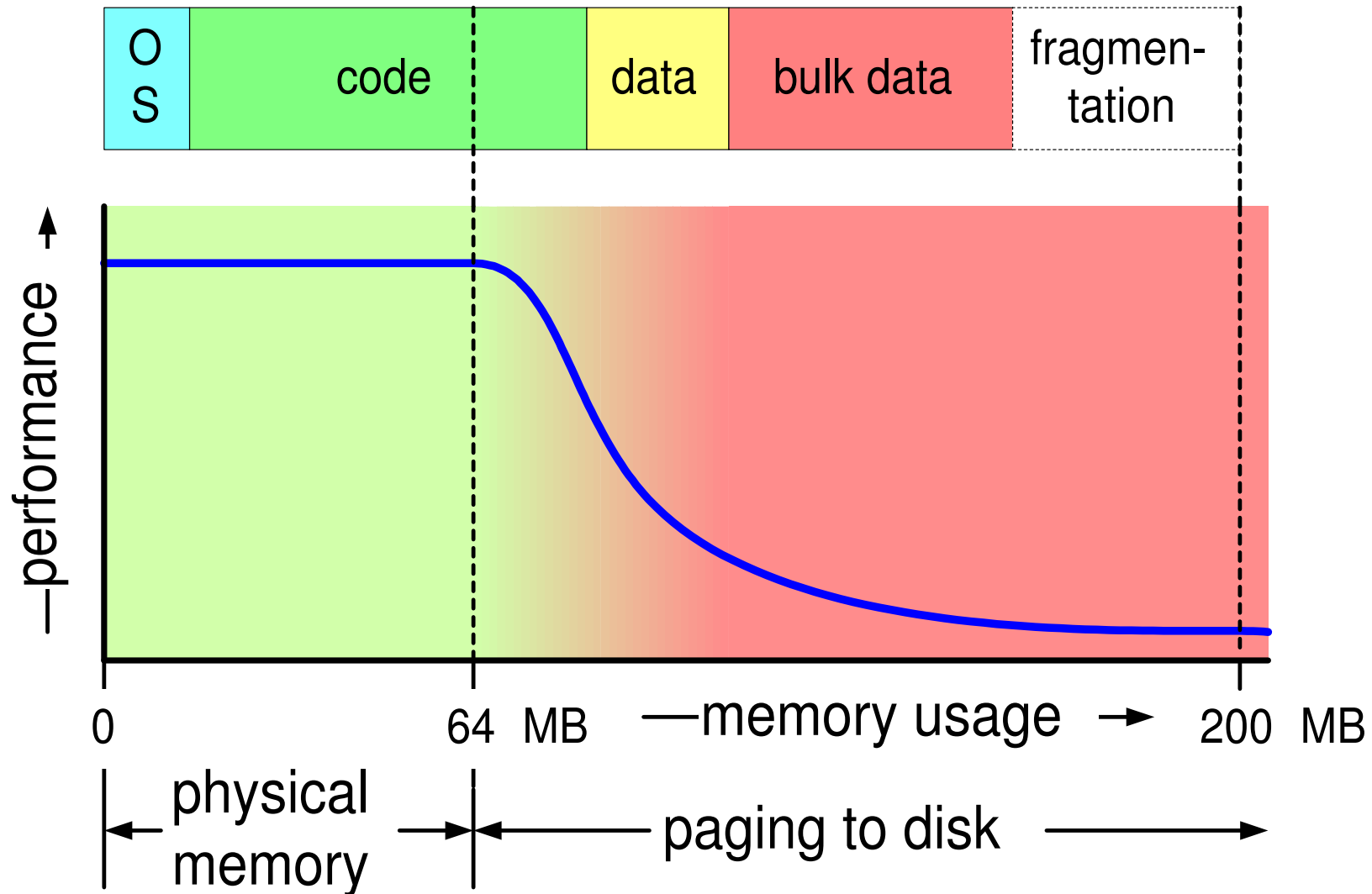

# Solution of memory performance problem

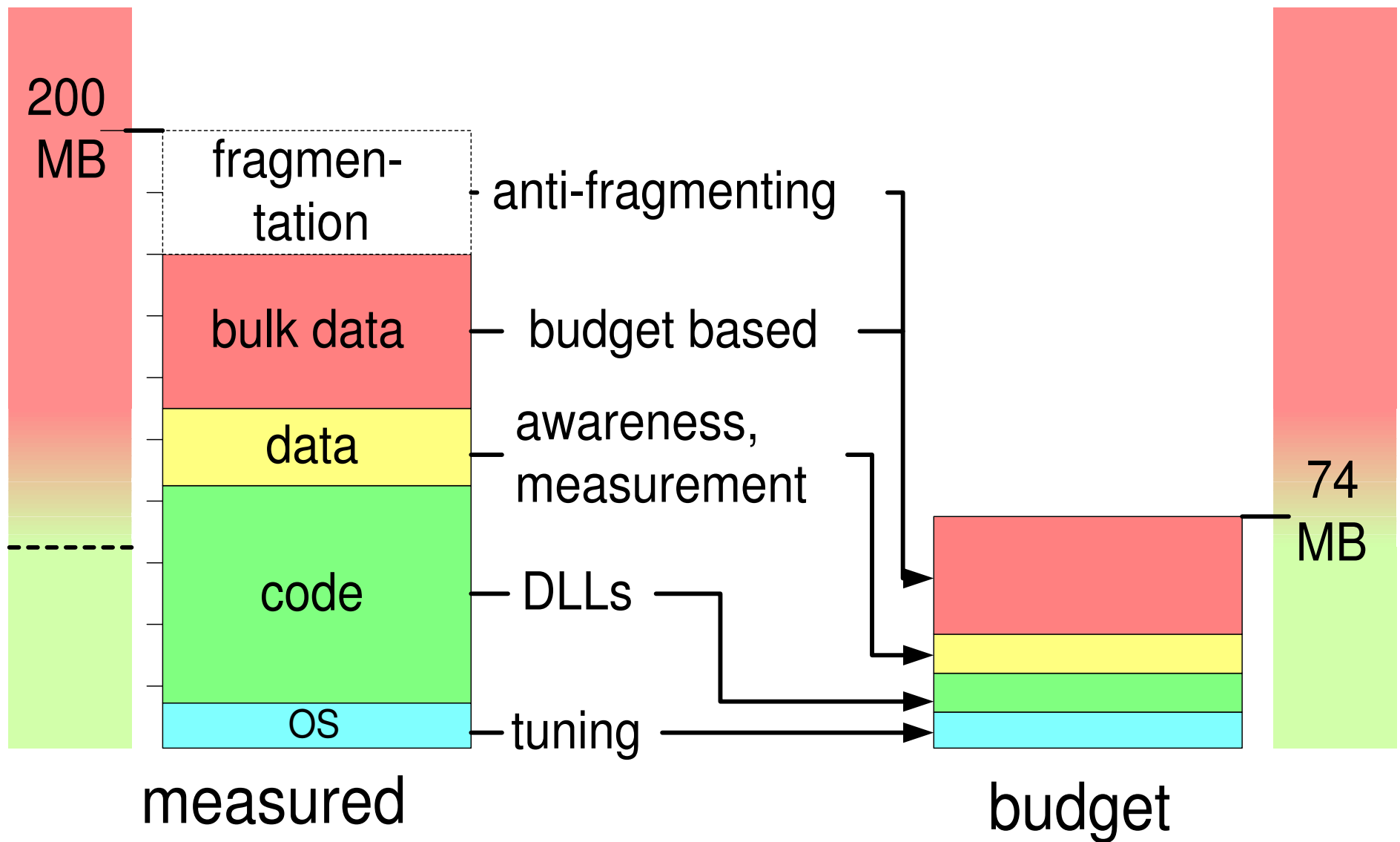

# Visualization memory use per process

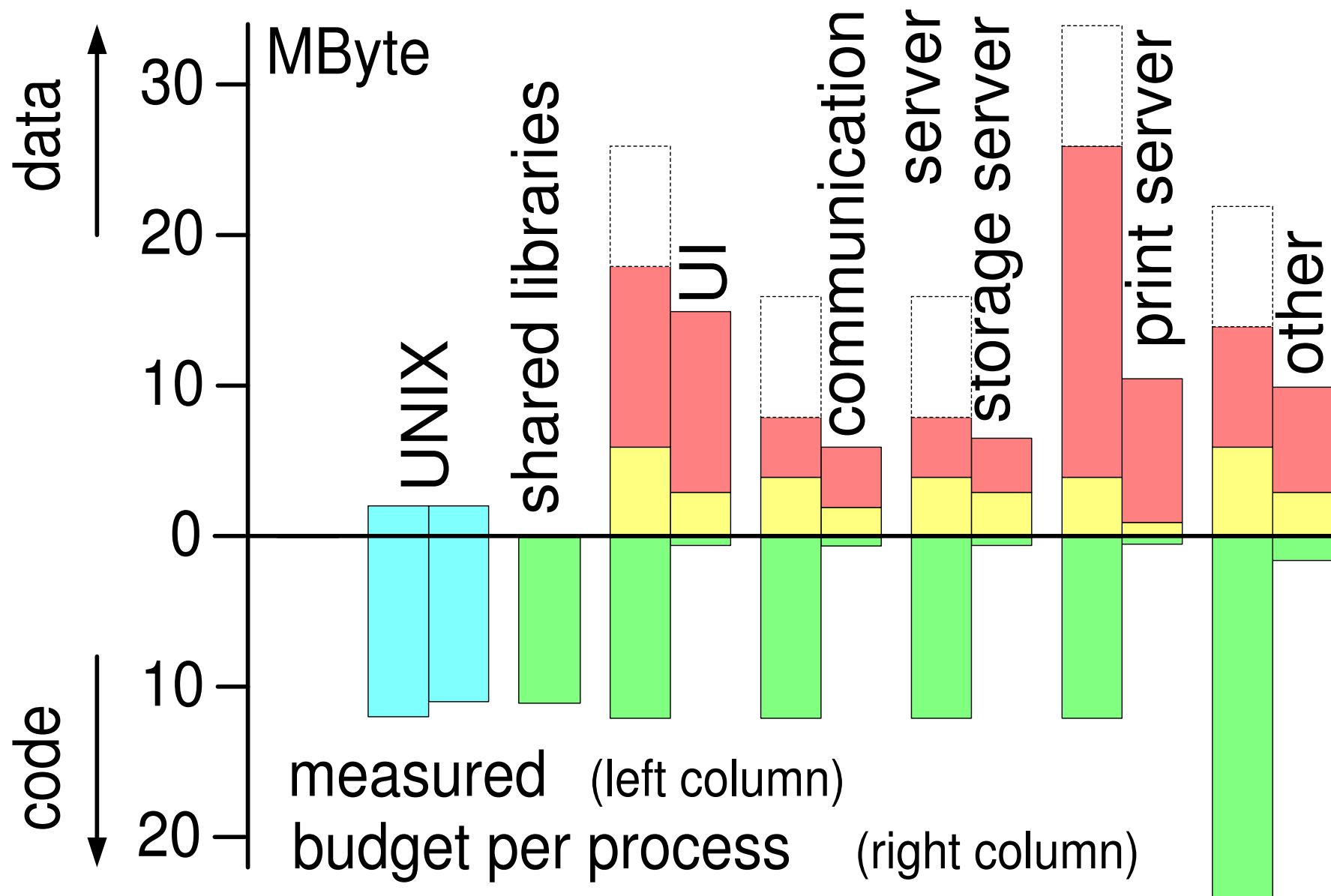

# Causes of Performance Problems other than Memory Use

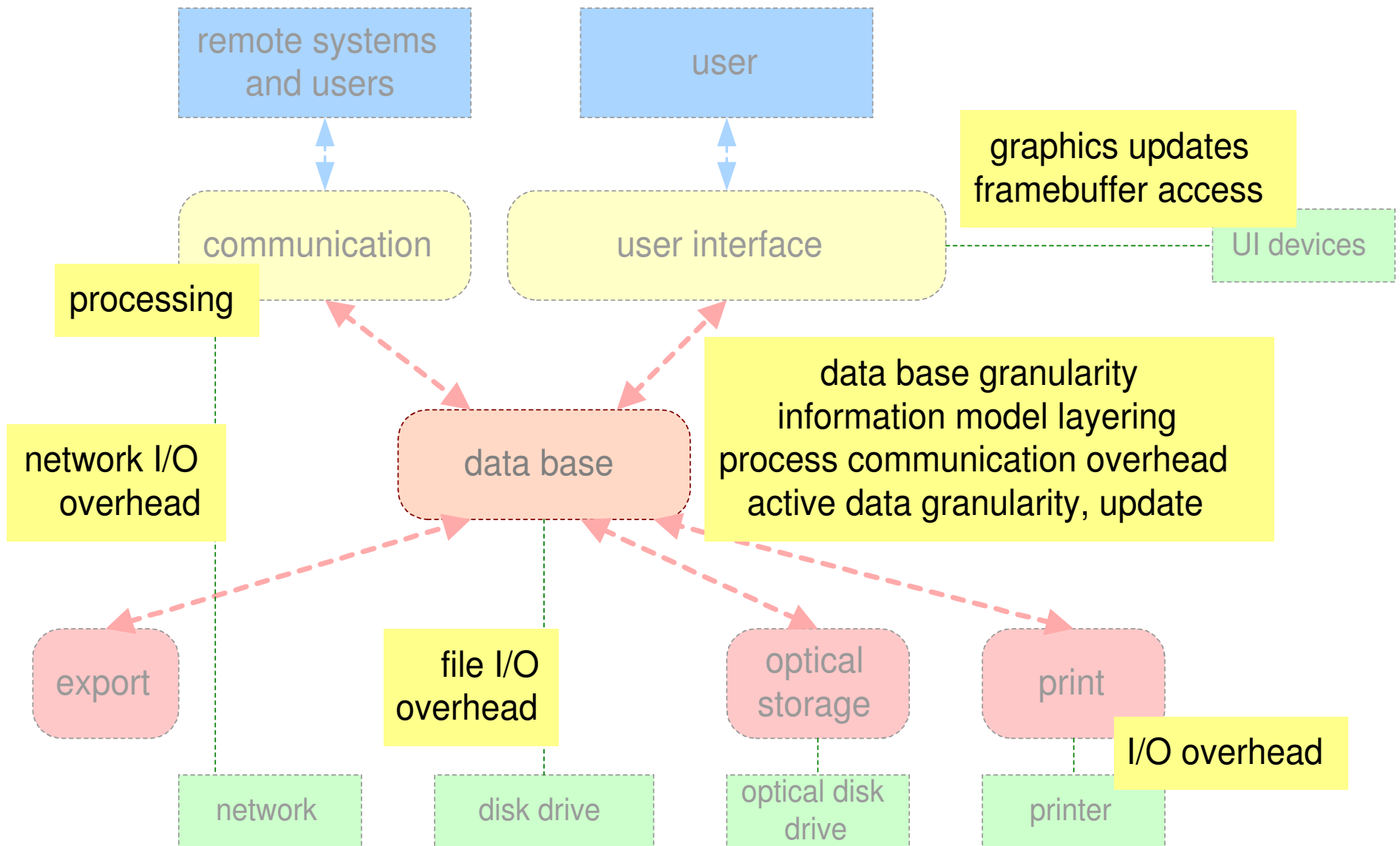

# Typical case URF examination

3 examination rooms connected to

1 medical imaging workstation + printer

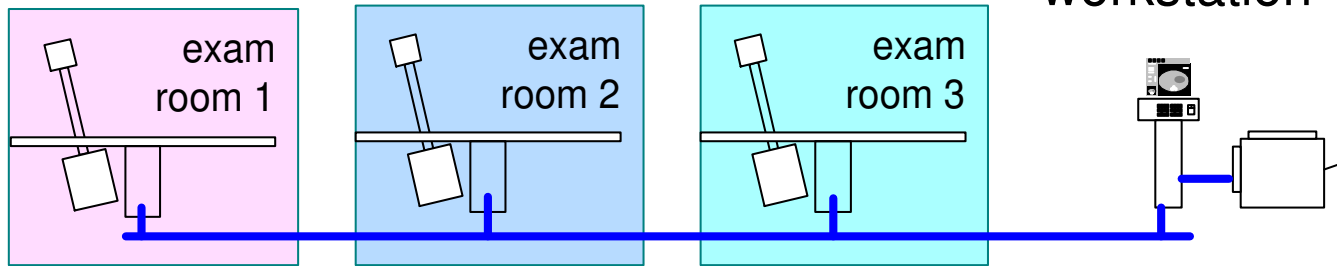

examination room: average 4 interleaved examinations / hour

image production: 20 1024<sup>2</sup> 8 bit images per examination



film production: 3 films of 4k\*5k pixels each

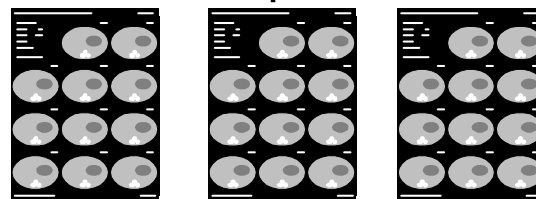

high quality output  
(bi-cubic interpolation)

# Thread of reasoning; phase 2

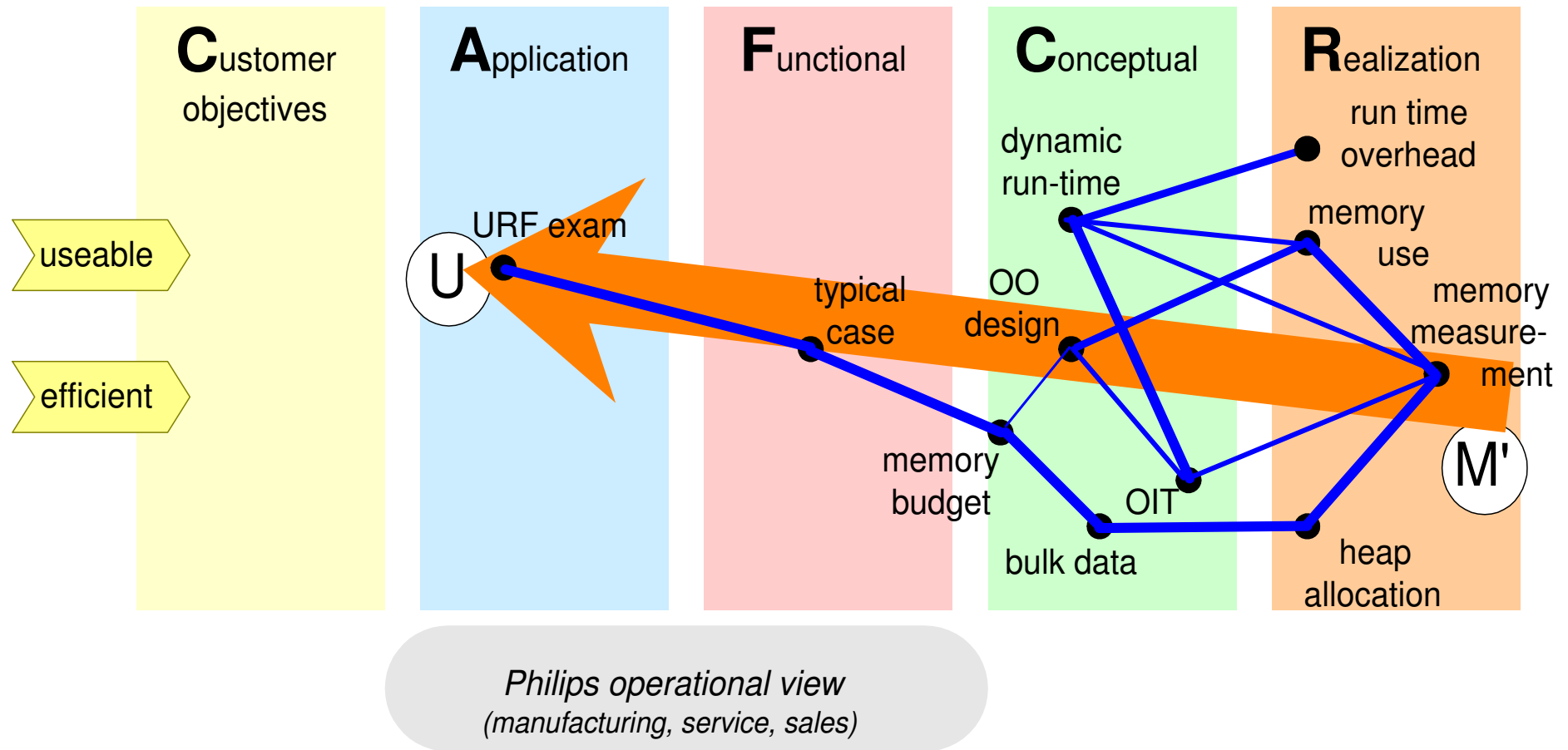

How to measure memory, how much is needed?  
from introvert to extrovert

# Radiologist workspots and activities

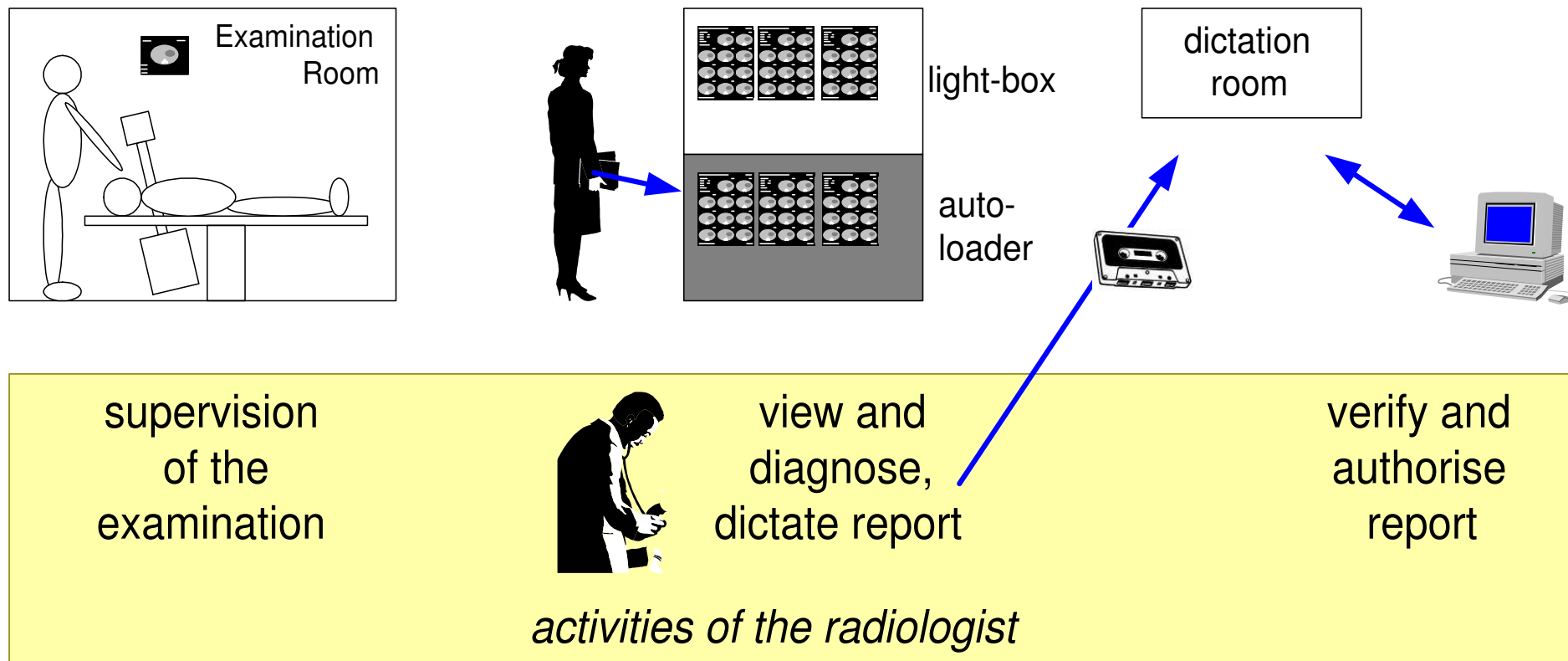

# Diagnosis in tens of seconds

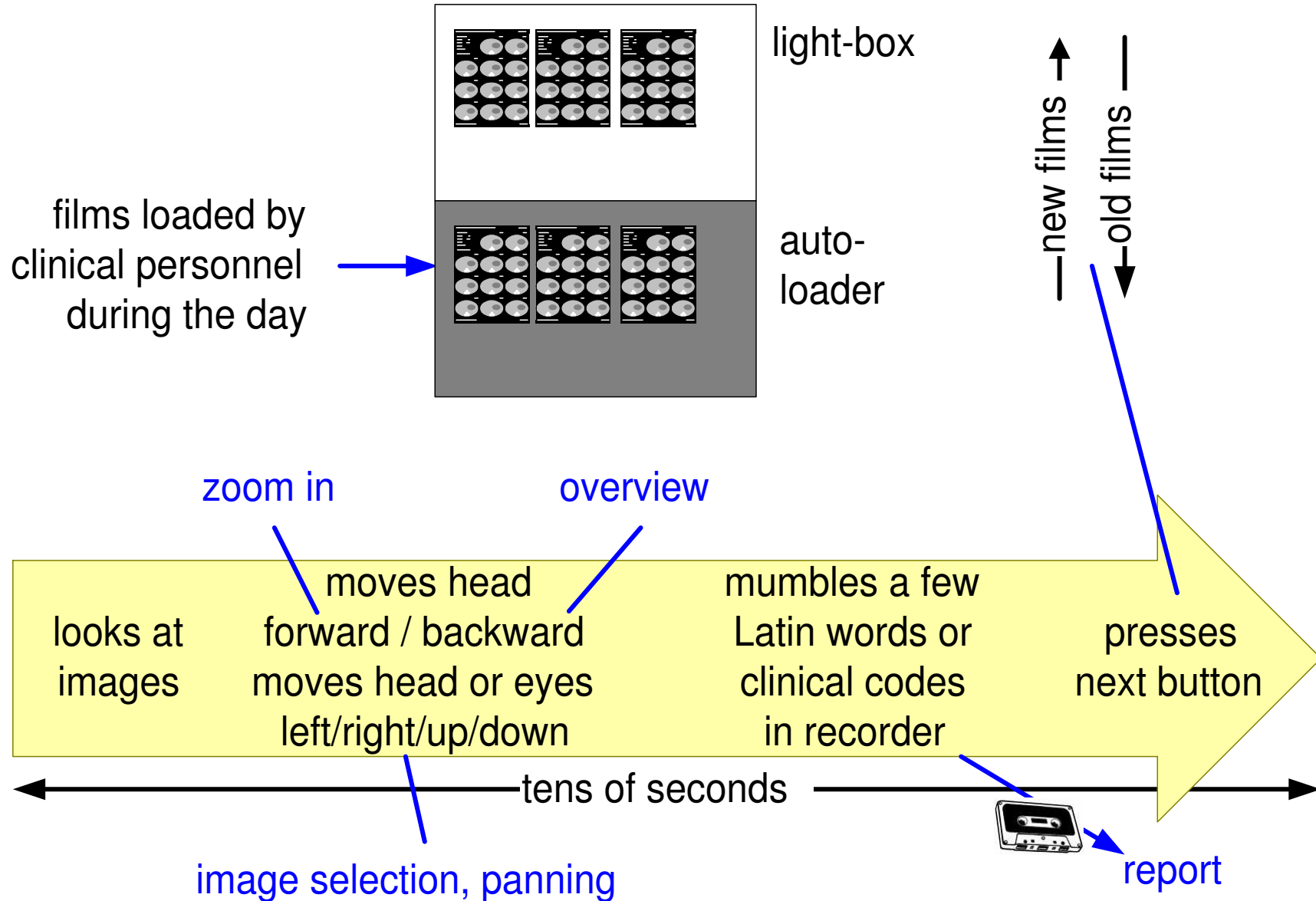

# SW Process structure 1991

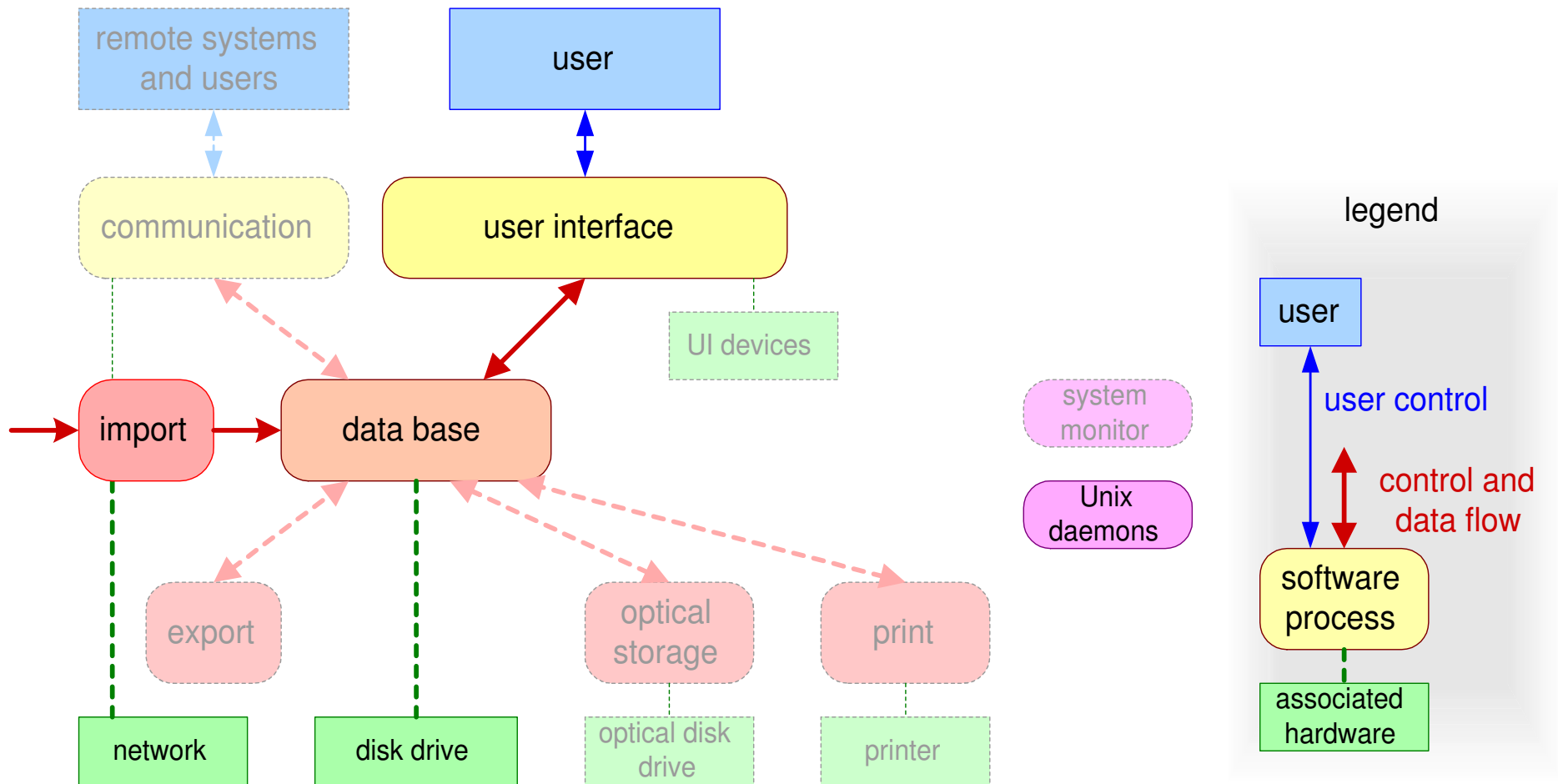

# SW layers 1991

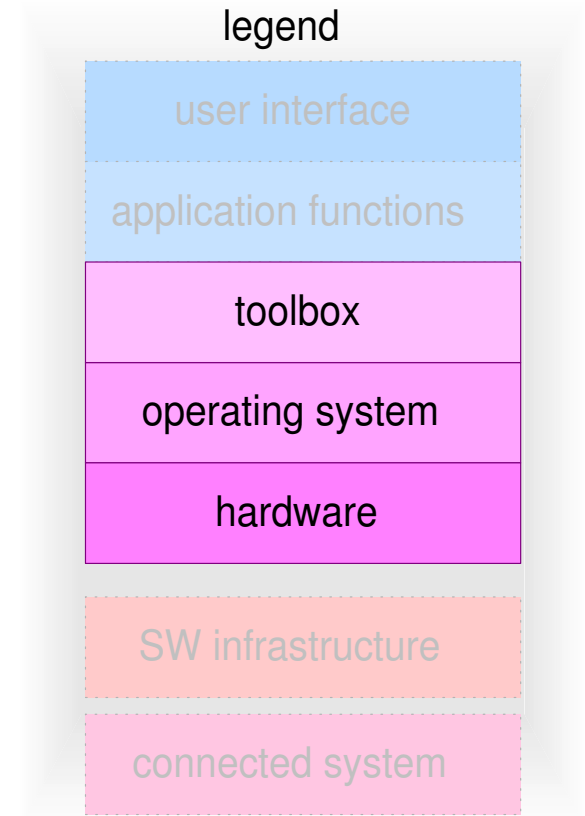
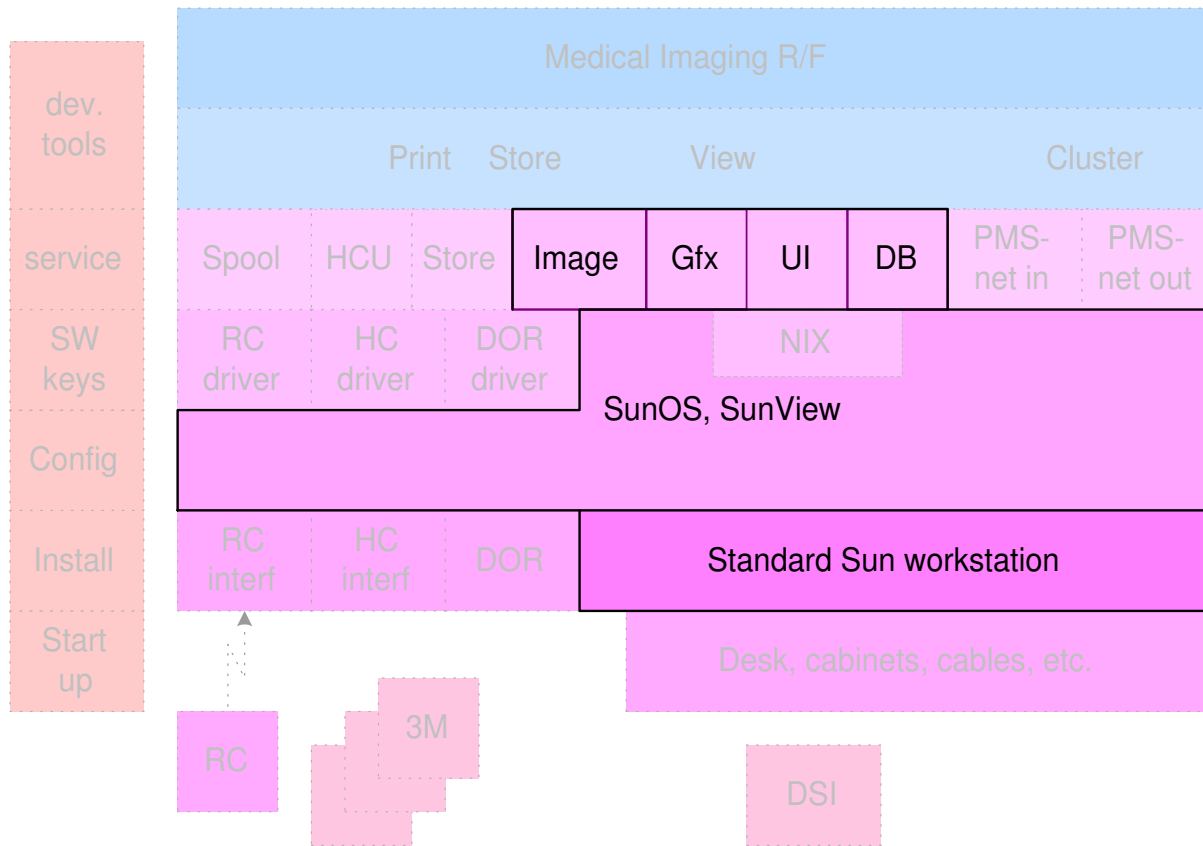

# Thread of reasoning; phase 3

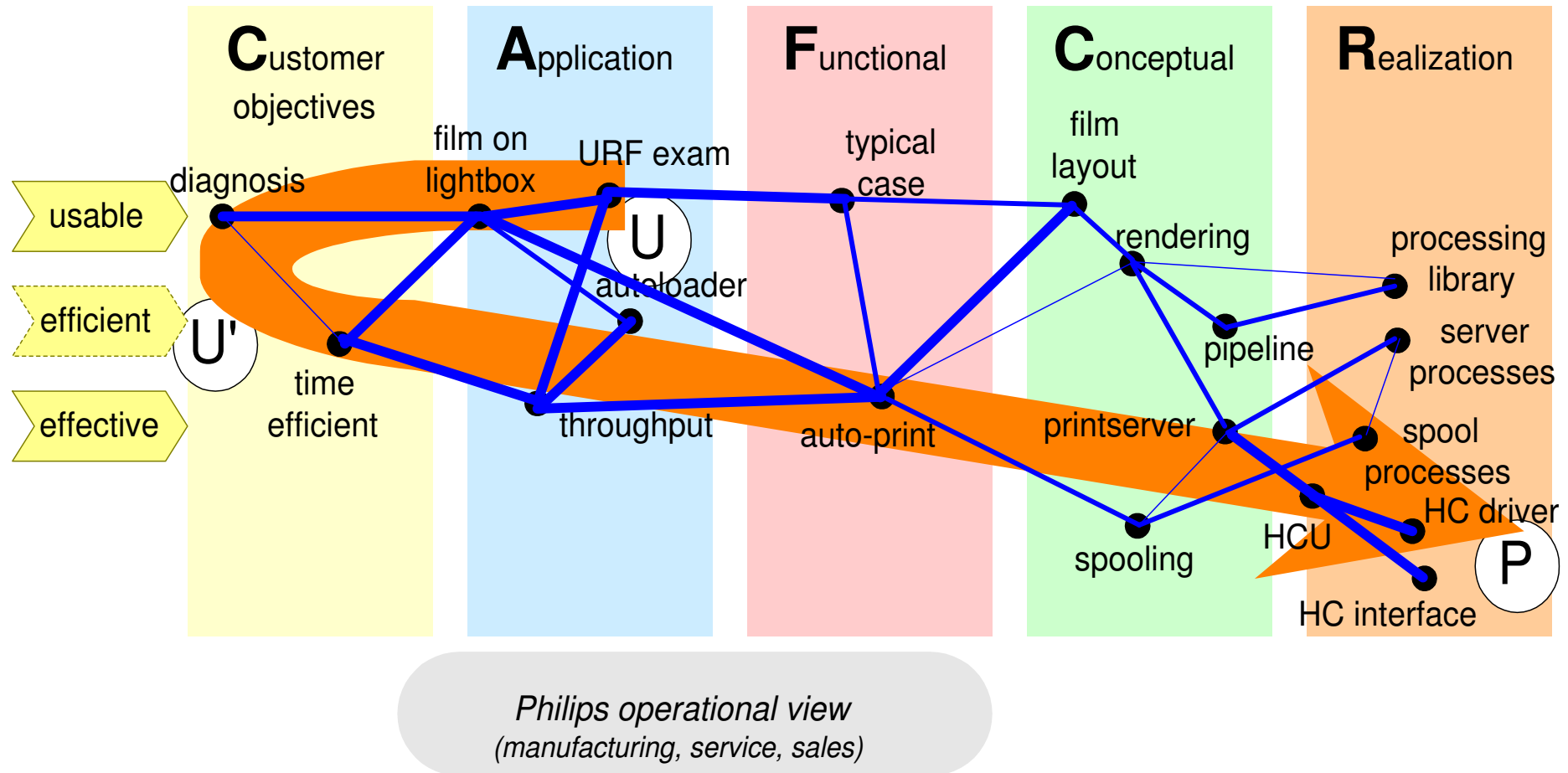

Radiologists diagnose from film, throughput is important  
 Extrovert view shows conceptual and realization gaps!

# Image quality and safety problem

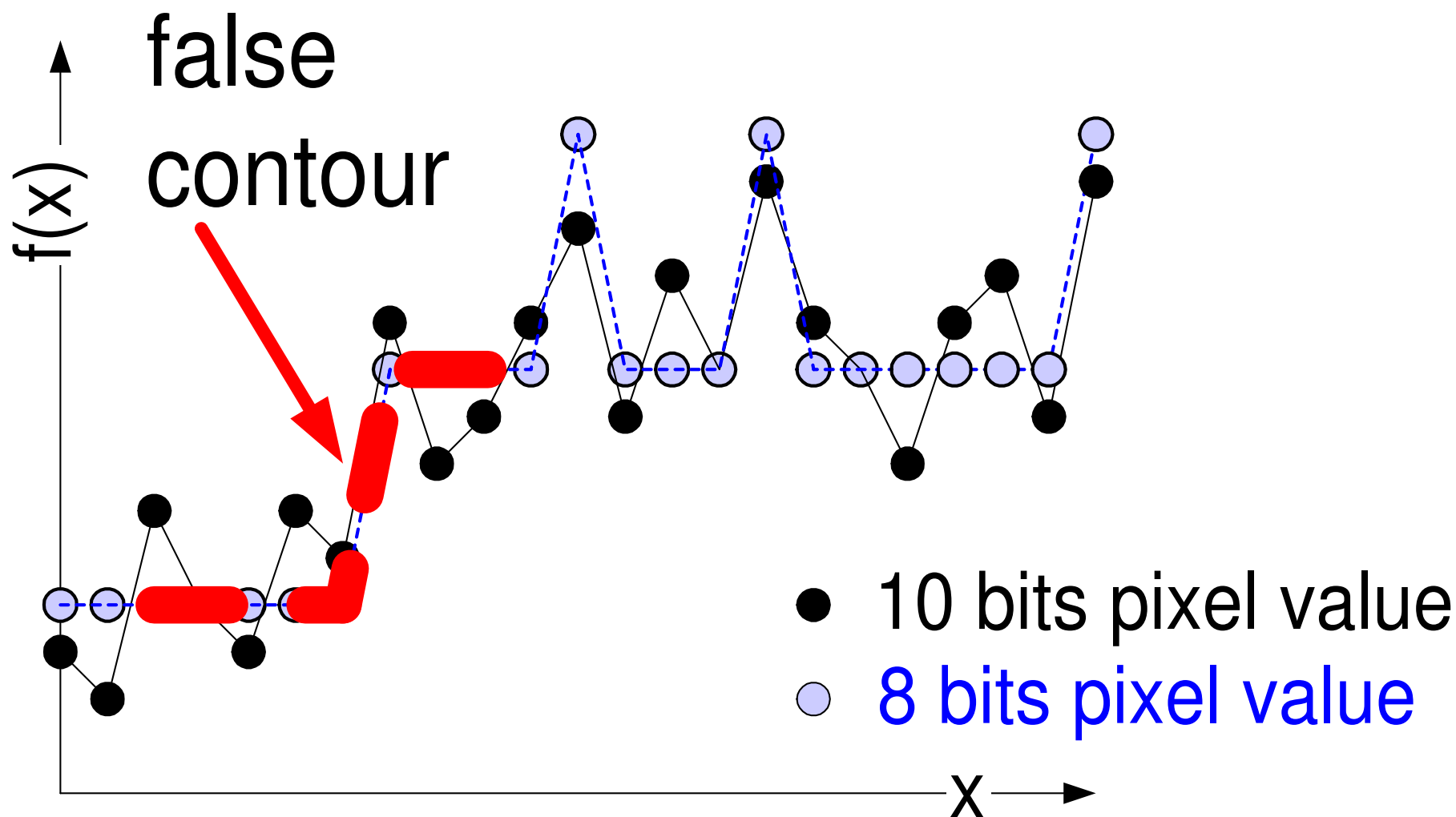

# Image Quality expectation WYSIWYG

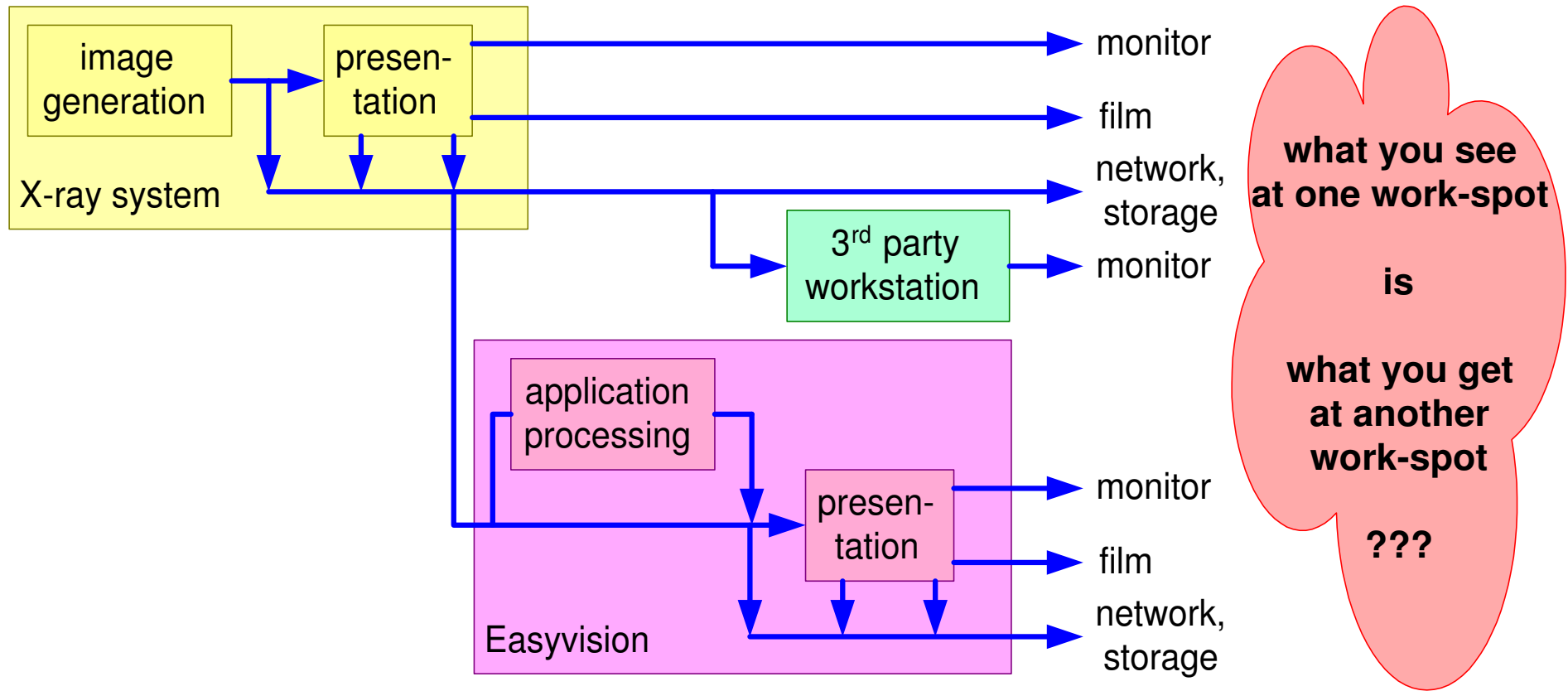

# Safety problem

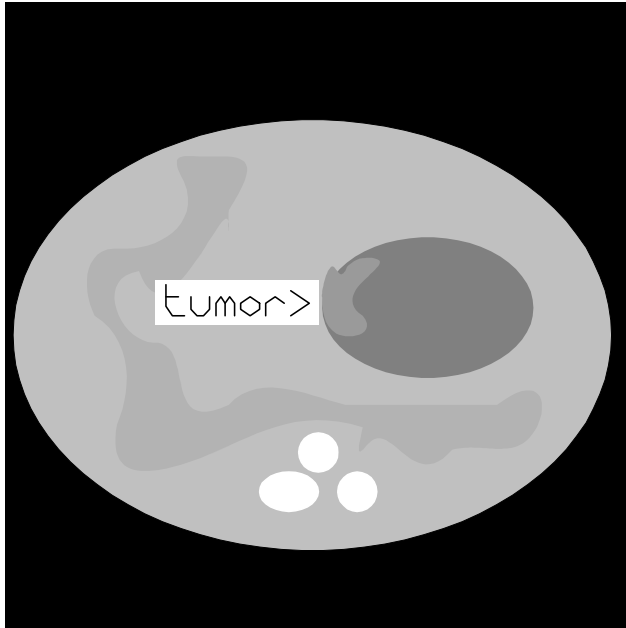

URF monitor output:  
fixed size letters at fixed grid

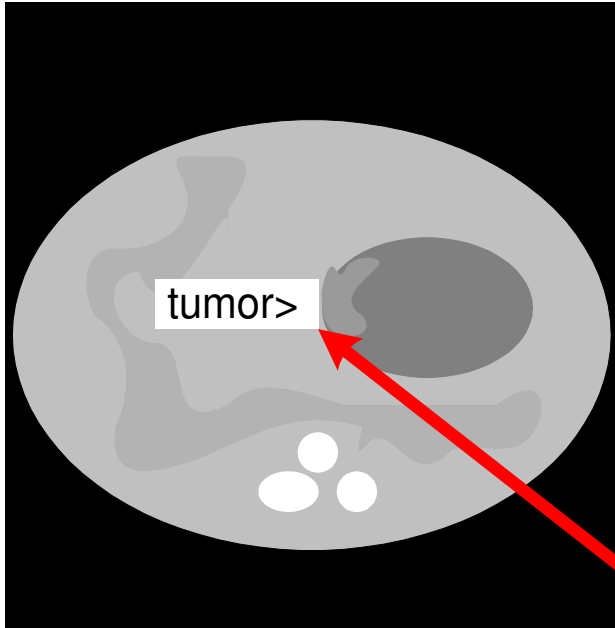

EV output: scaleable fonts in graphics overlay

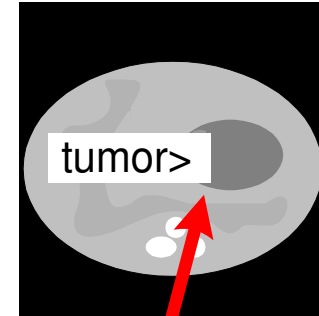

for user readability the font-size was determined "intelligently"; causing a dangerous mismatch between text and image

# Thread of reasoning; phase 4

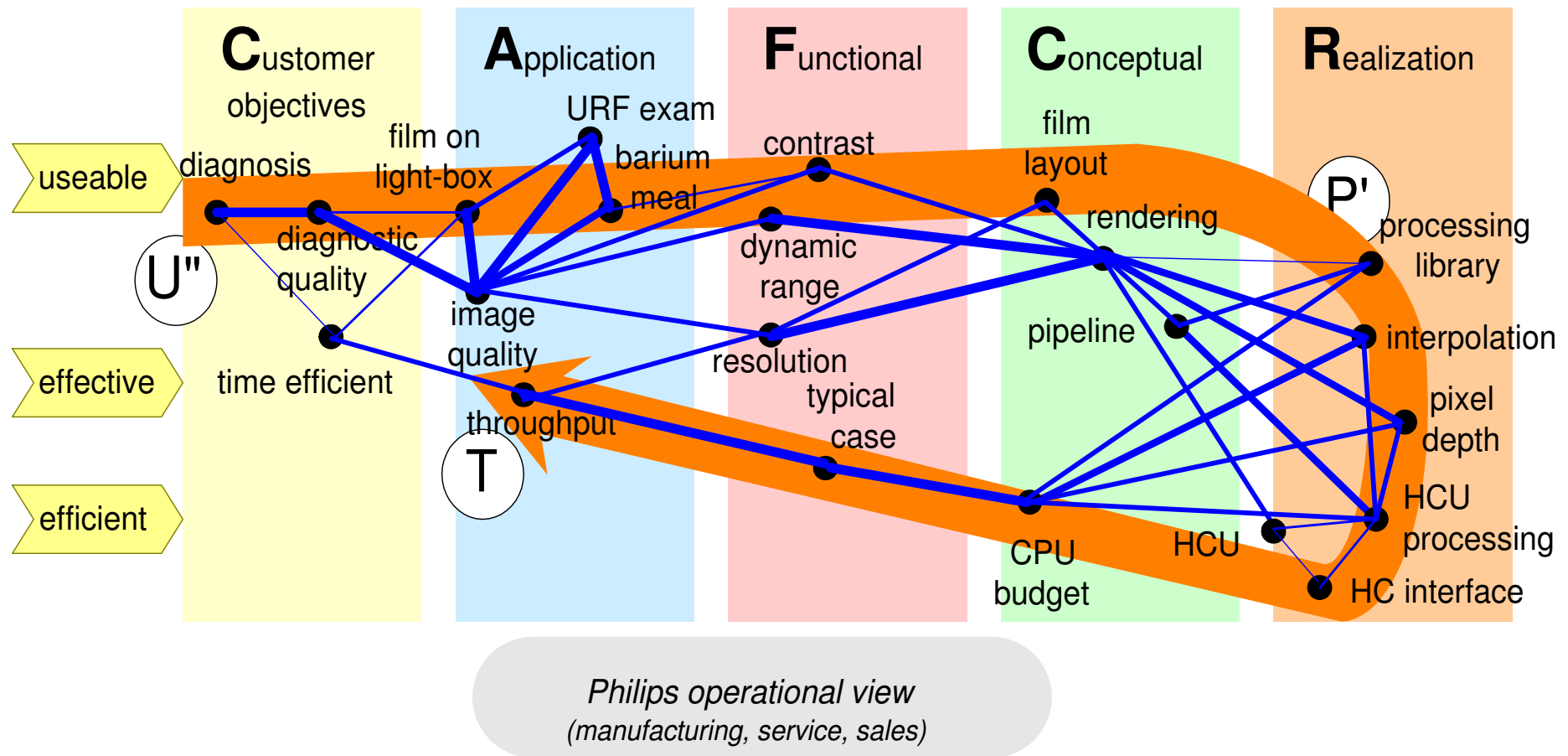

from extrovert diagnostic quality, via image quality, algorithms and load, to extrovert throughput

# Thread of reasoning; phase 5

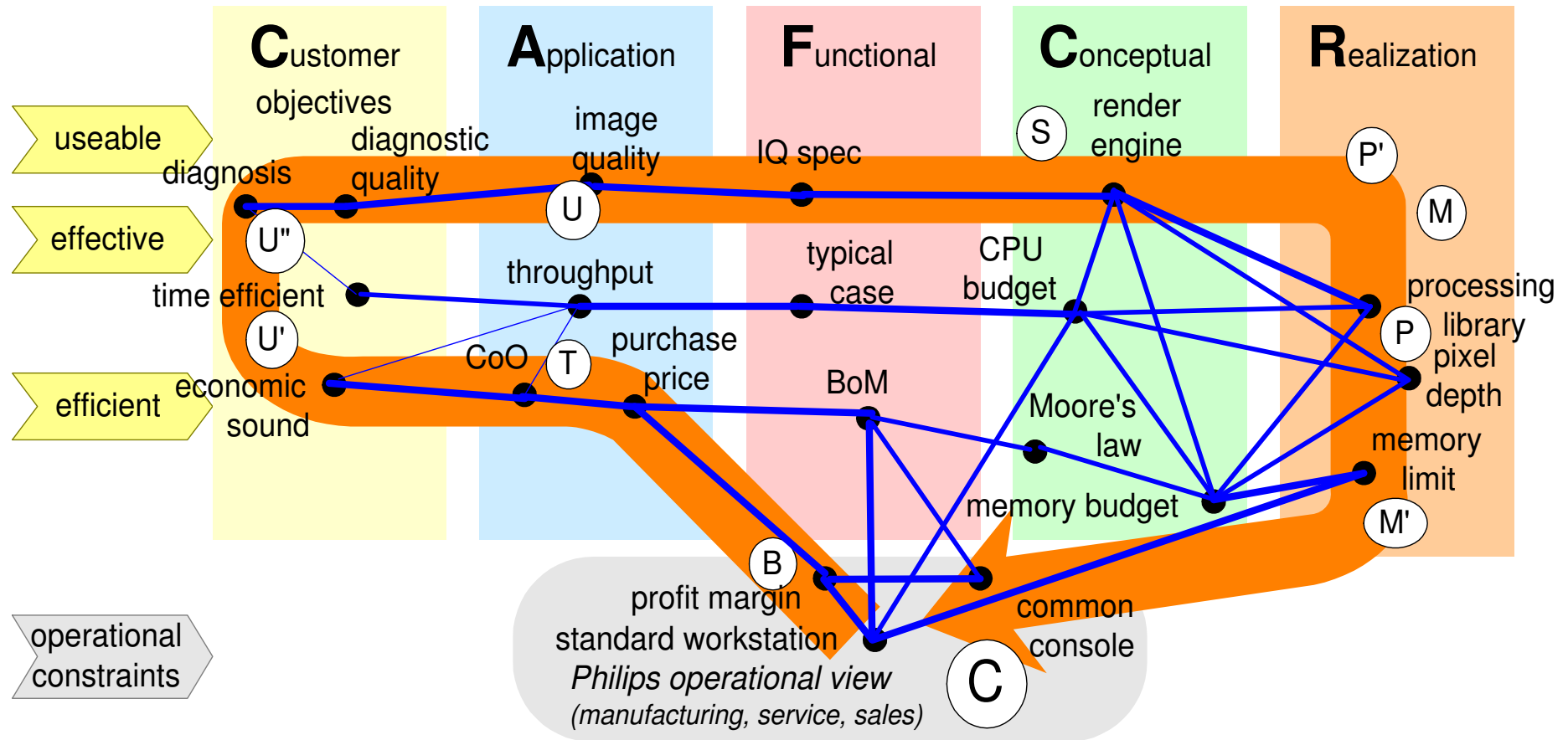

cost revisited in context of clinical needs and realization constraints; note: original threads are significantly simplified

# Strategy Development Work Flow Products

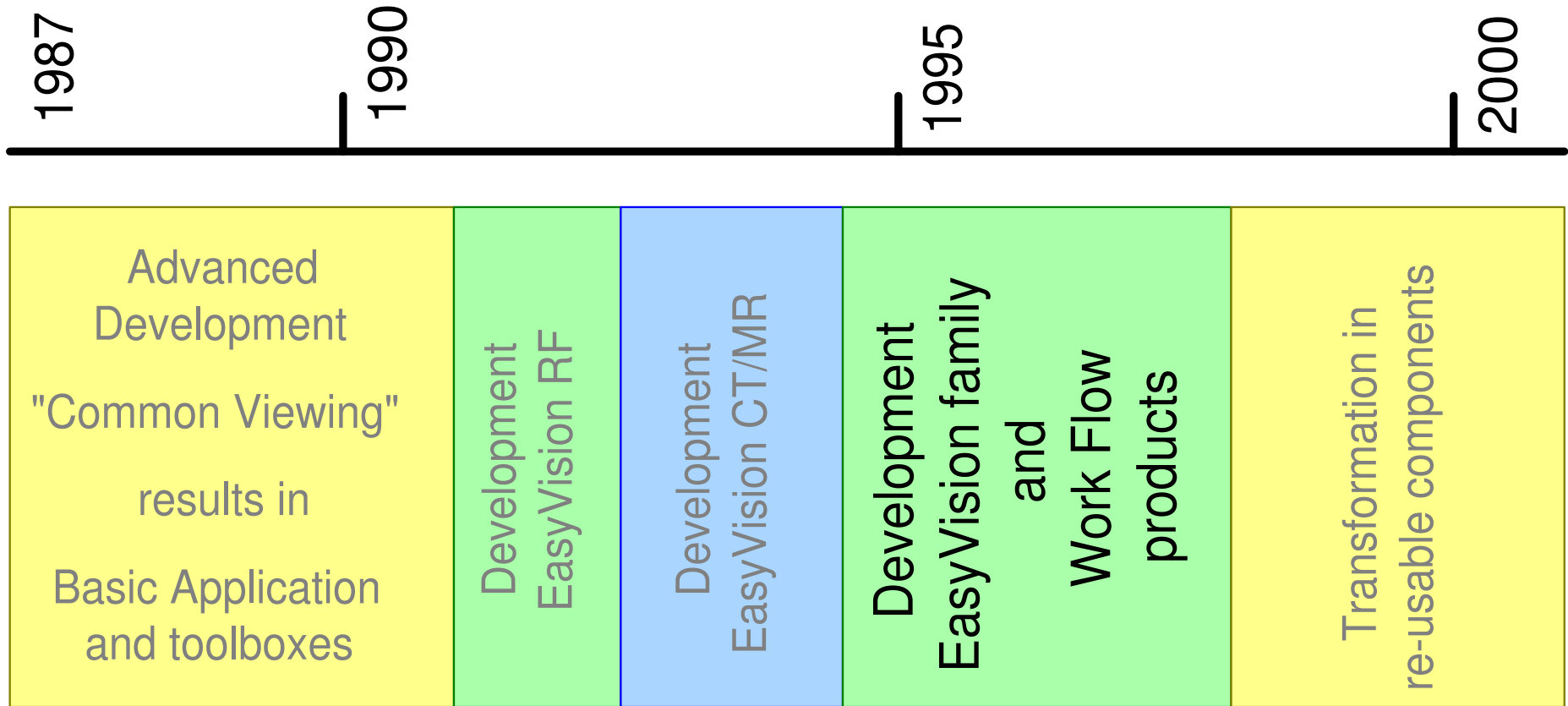

# The clinical context of the radiology department

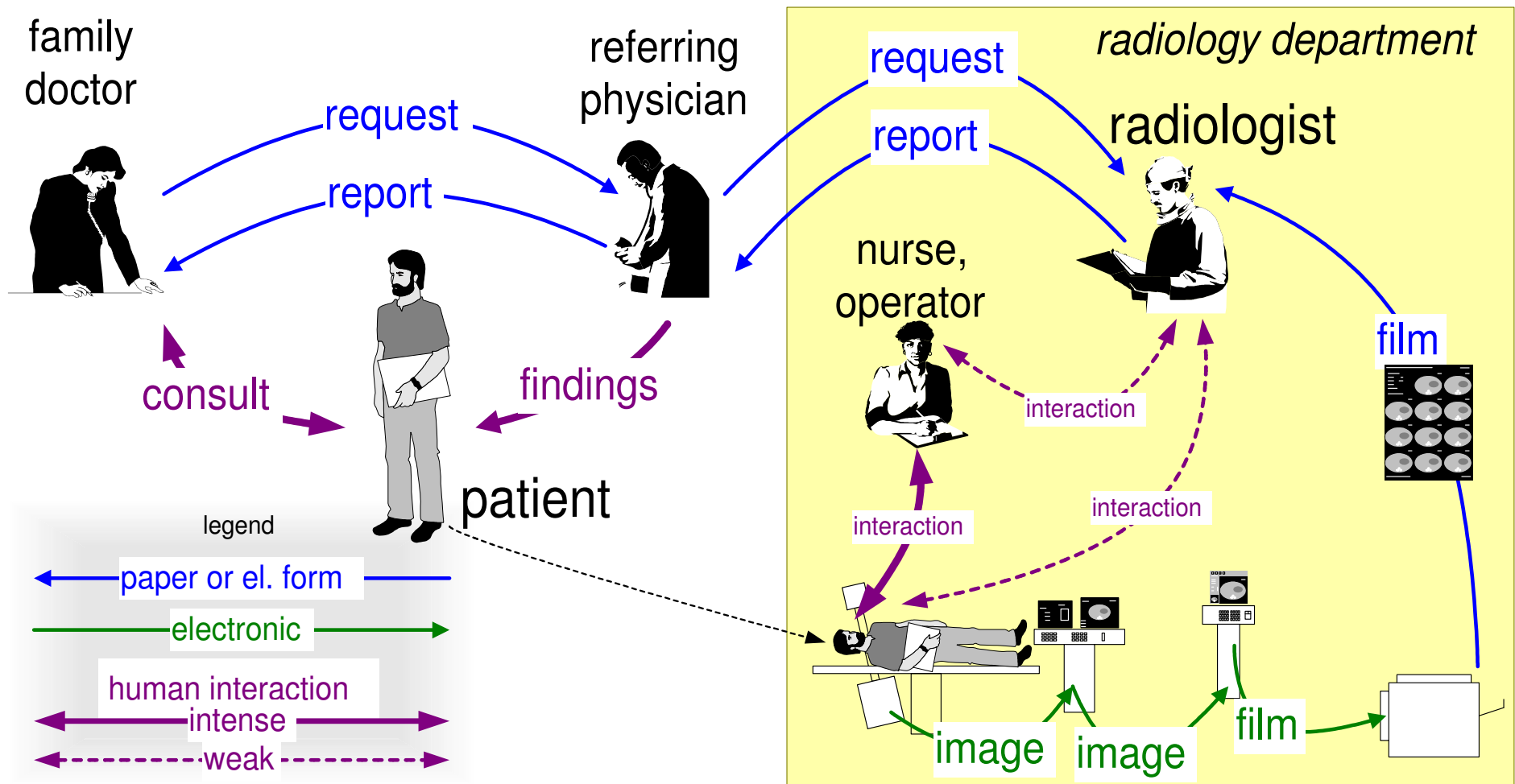

# The financial context of the radiology department

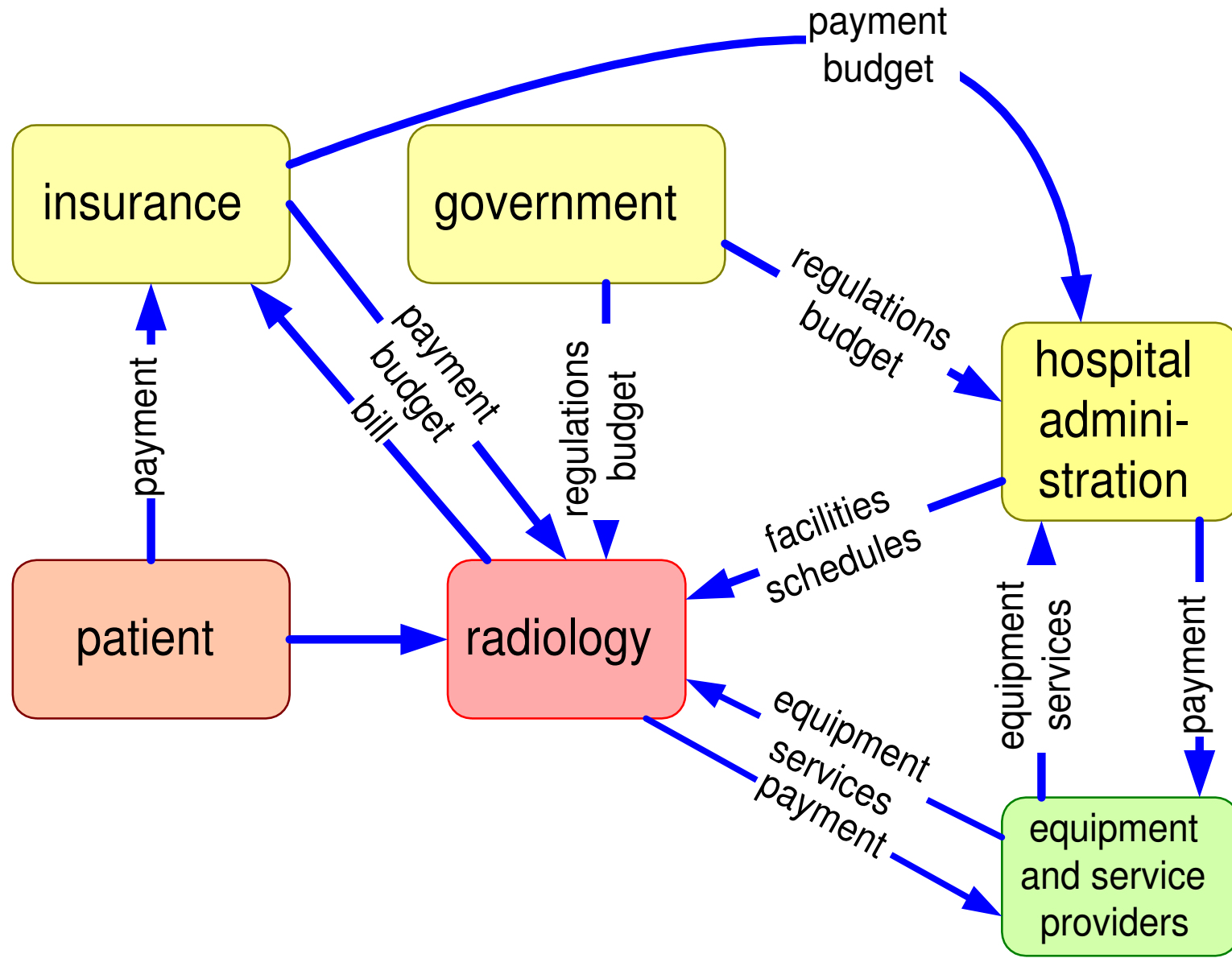

# Key drivers, application drivers and requirements

Customer  
key drivers

derived  
Application drivers

report quality

selection of relevant material  
use of standards

diagnostic quality

acquisition and viewing settings  
contrast, brightness and resolution of light-box

safety and liability

clear patient identification  
left right indicators  
follow procedures  
freeze diagnostic information

cost per diagnose

interoperability over systems and vendors  
multiple images per film  
minimise operator handling  
multiple applications per system

time per diagnose

diagnose at light-box with films  
all preparation in exam room

many  
to  
many

Requirements

import	
auto-print	
parameterized layout	
spooling	
storage	
navigation / selection	
auto-delete	
viewing	
contrast / brightness	
zoom	
annotate	
export	<i>functionality</i>
system response	
system throughput	
image quality	
annotation	
material cost	
operational cost	<i>qualities</i>
shared information model	
viewing settings	
patient, exam info	
	<i>interfaces</i>

# Clinical information flow

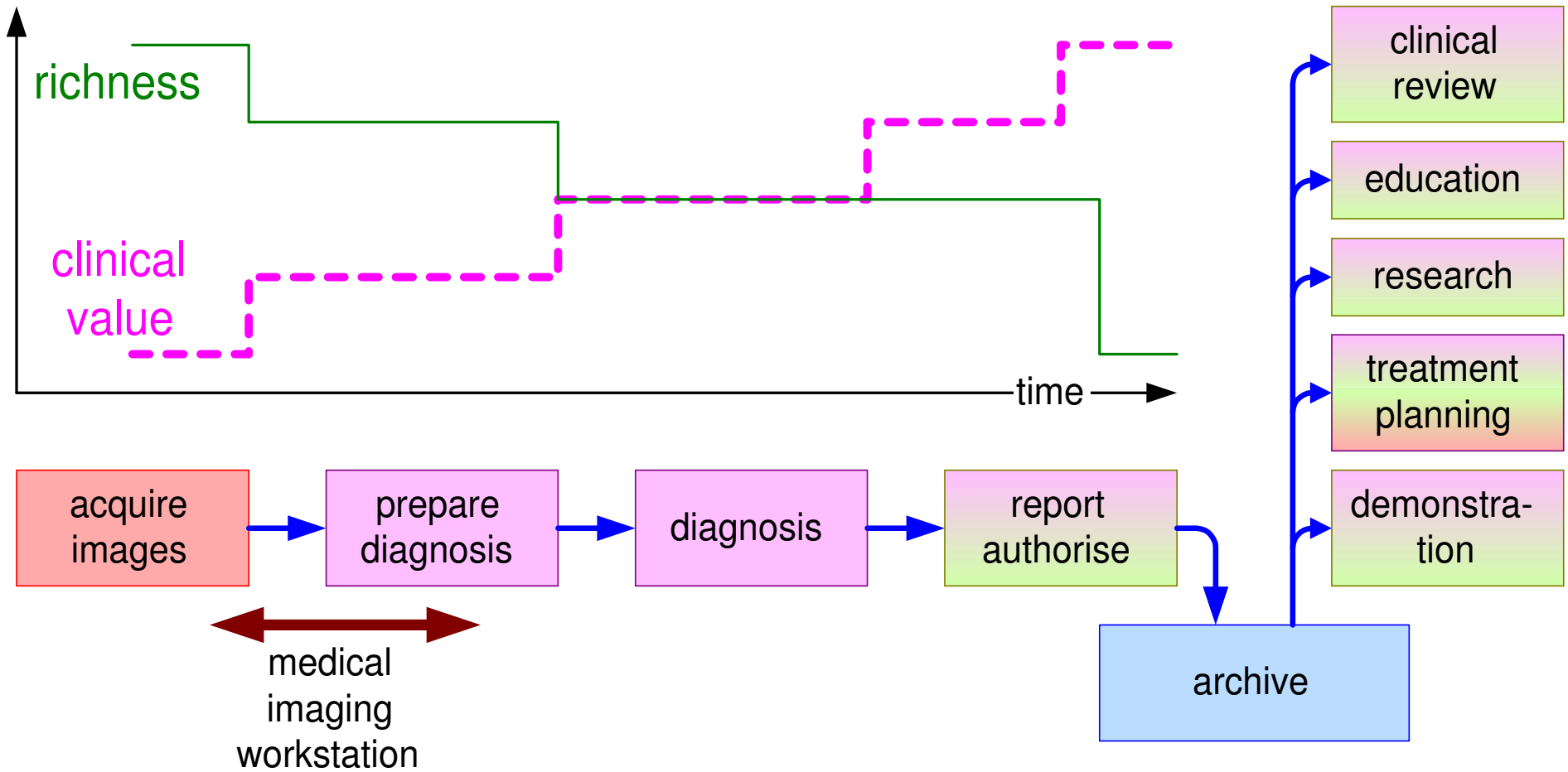

# Application layering of IT systems

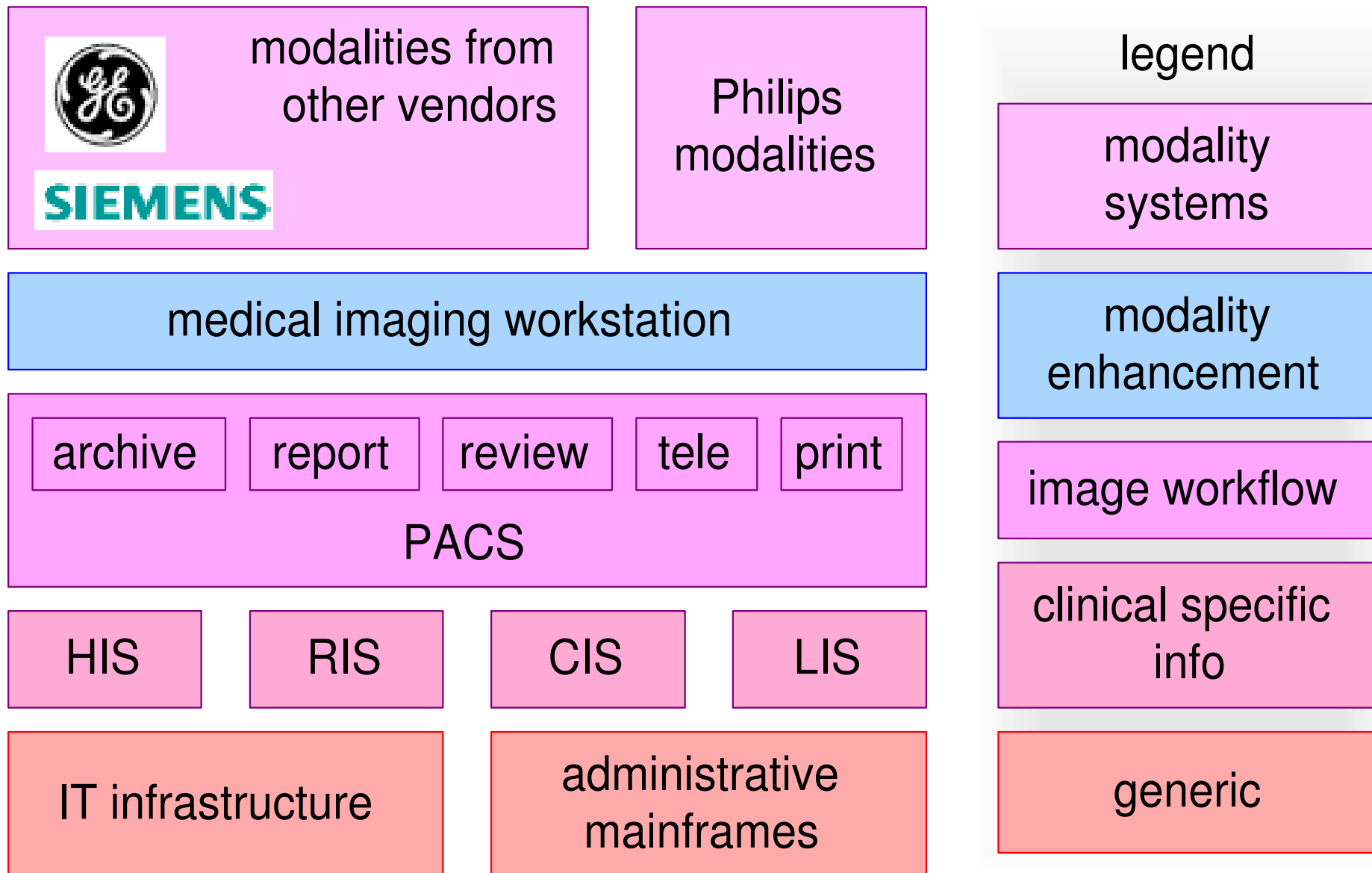

# Reference model for healthcare automation

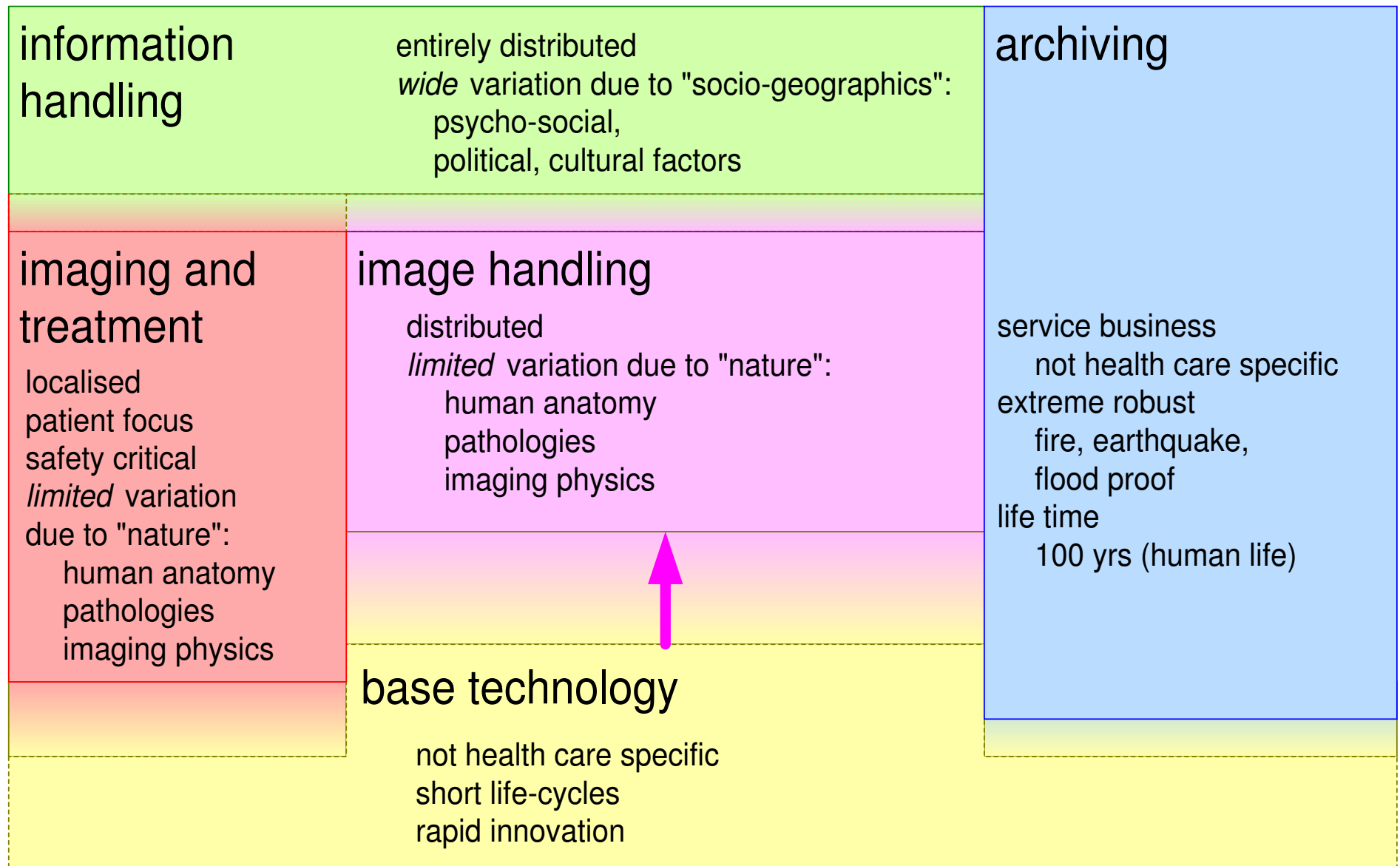

# Information model, standardization for interoperability

high innovation rate

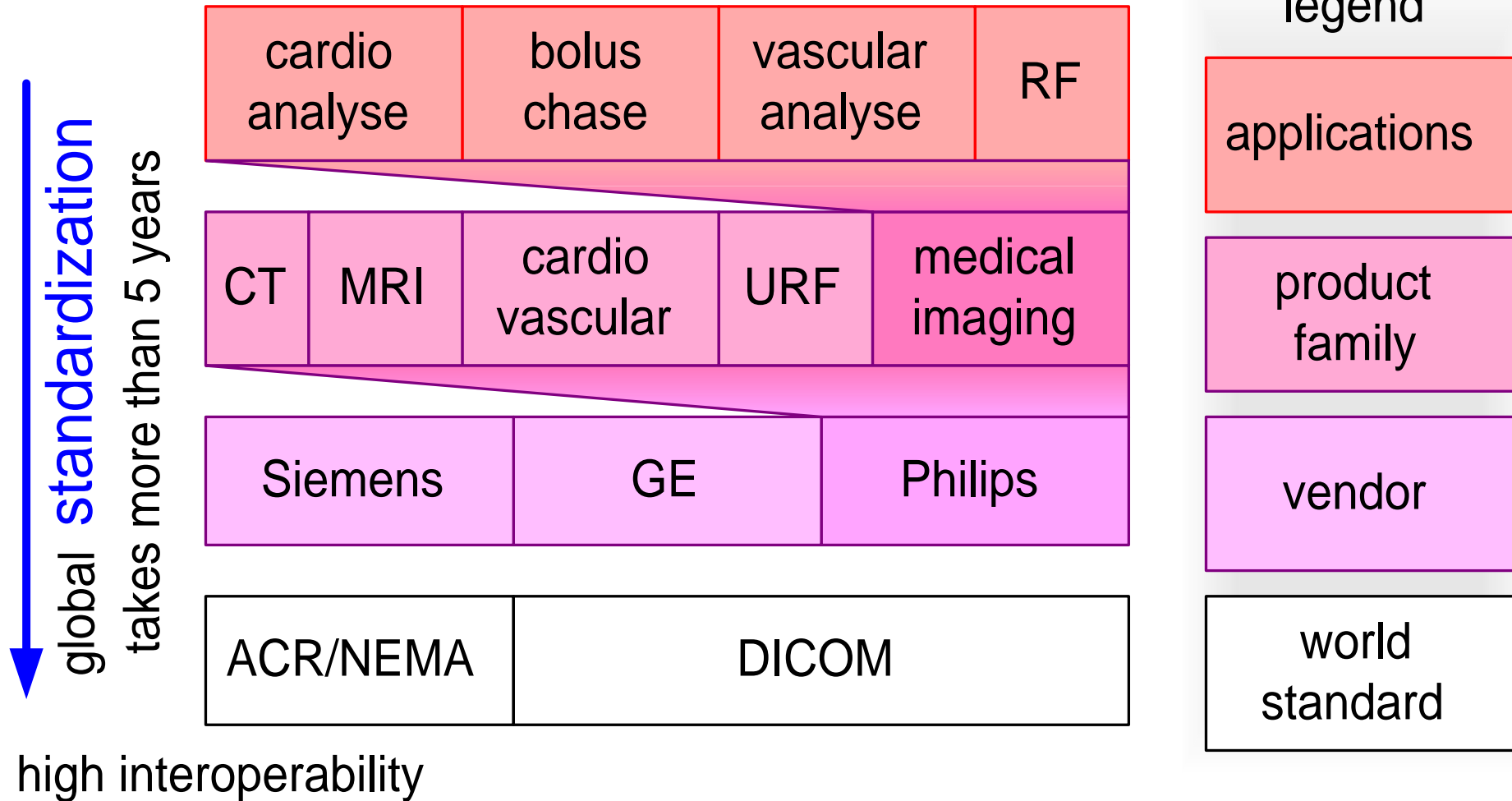

# Example CT/MR department

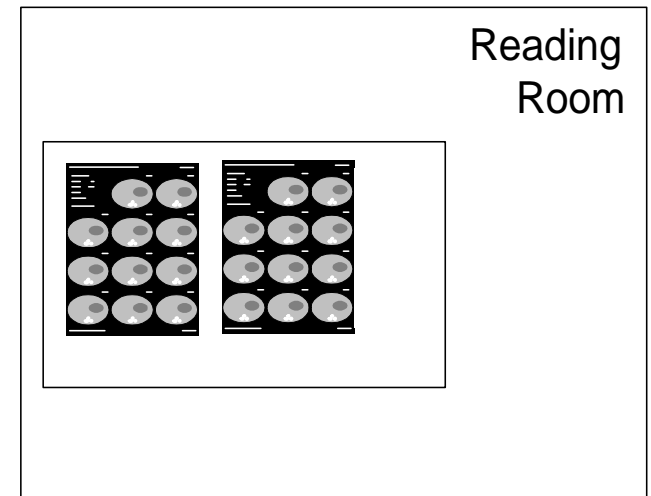
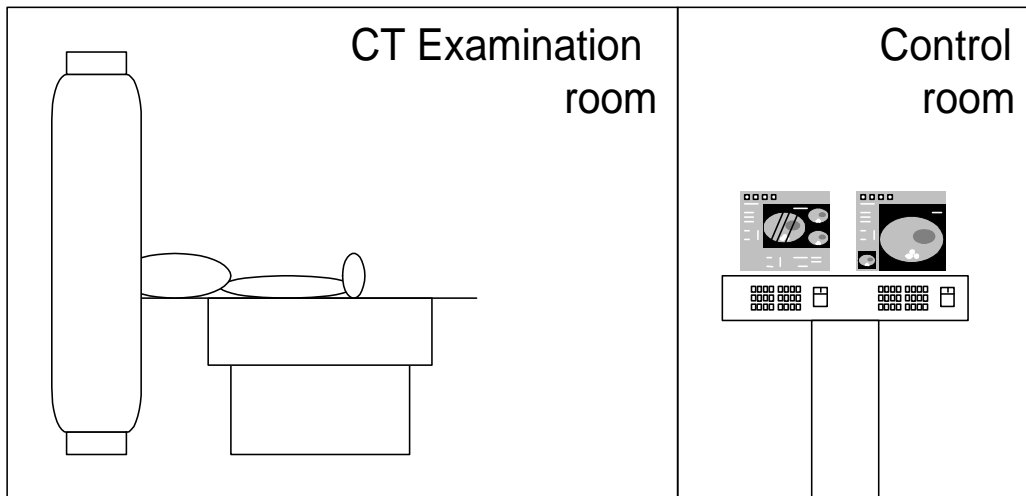
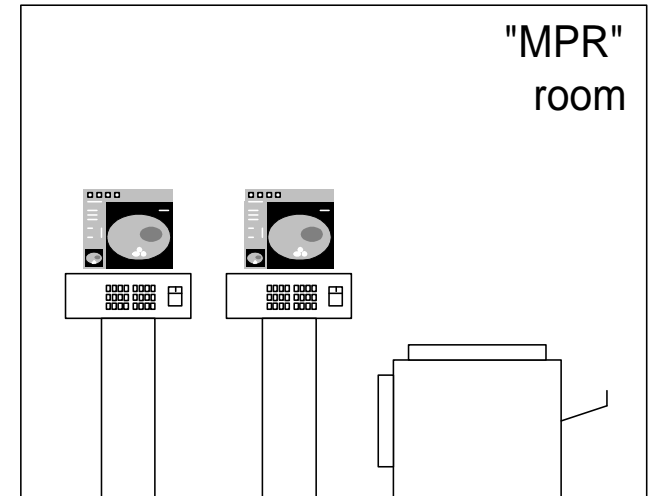
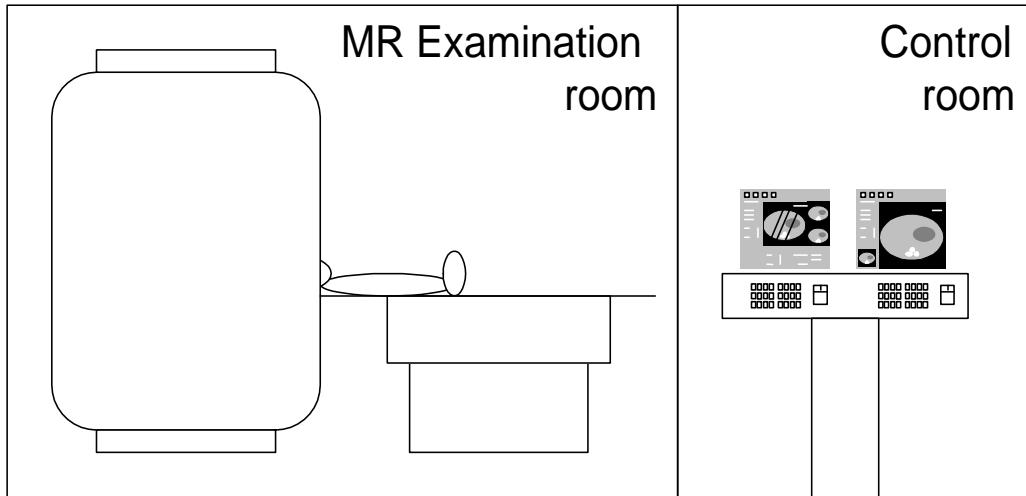

# Medical Imaging Competitive Positioning

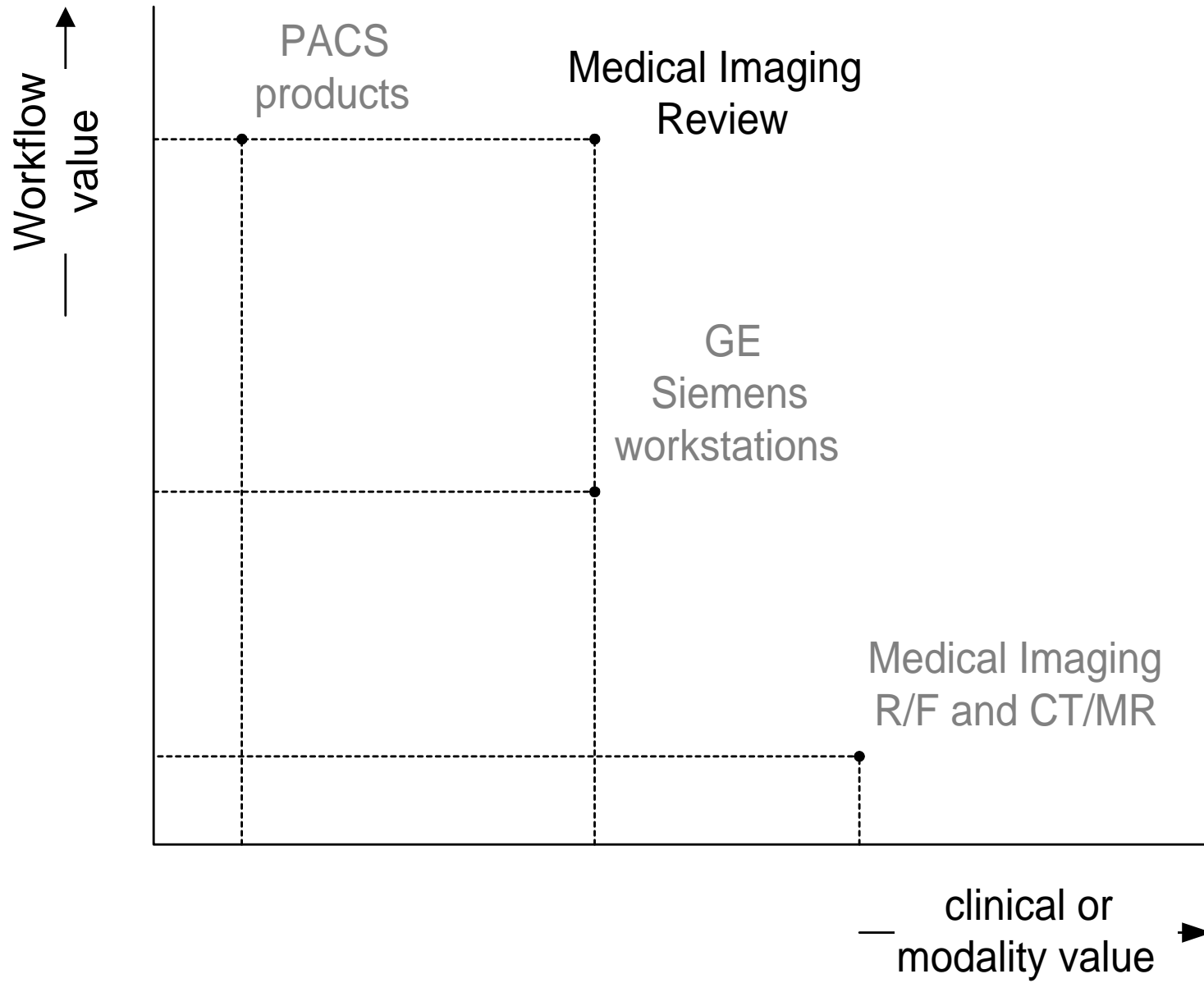

# Radiology Department

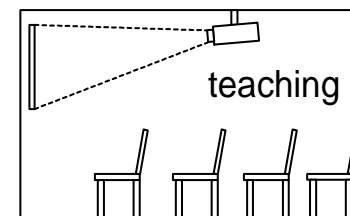
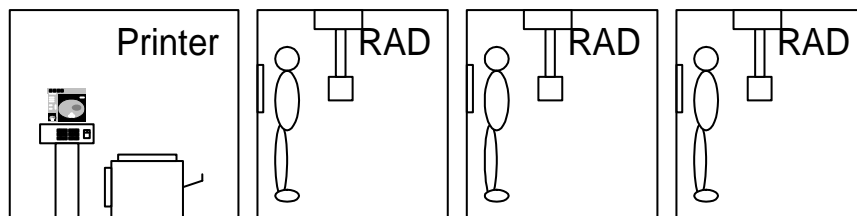
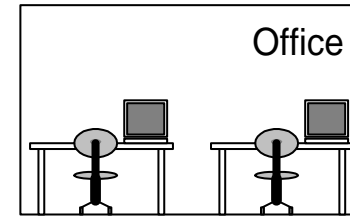
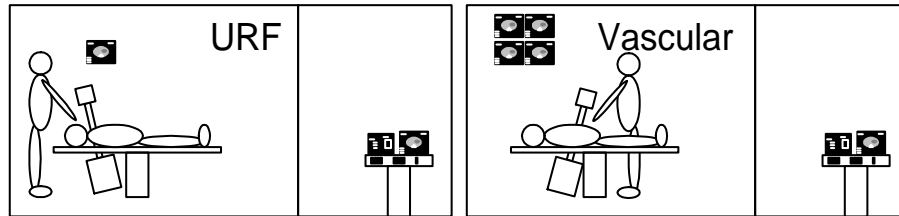
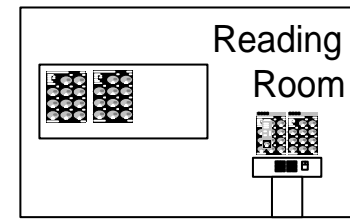
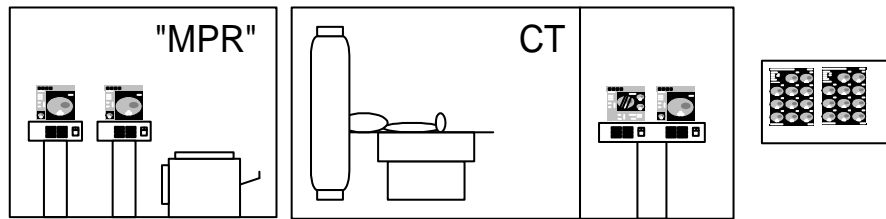
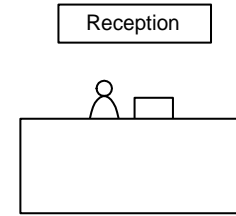
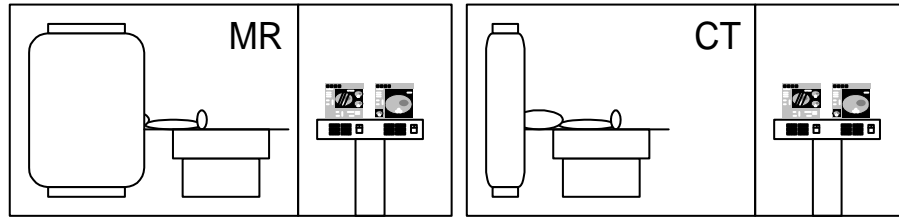

# Vision: Medical Imaging in Healthcare

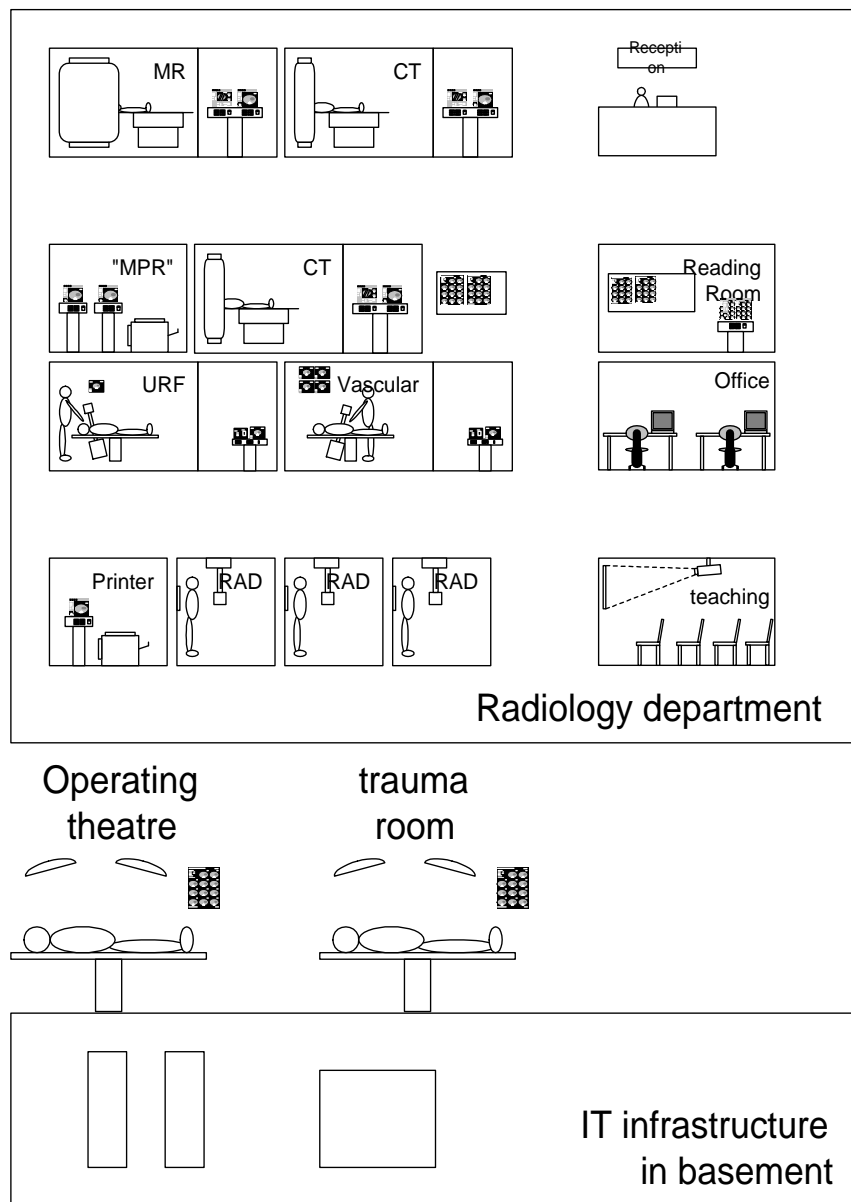

Radiologist at home

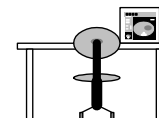

Radiologist somewhere in the hospital

Radiologist at other hospital

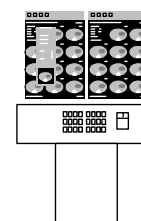

Referring Physician

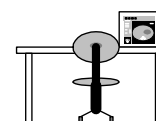

Referring Physician

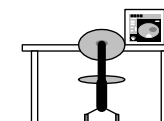

Conference room

