

# Challenges of Digital Engineering

by *Gerrit Muller* USN-SE

e-mail: gaudisite@gmail.com

www.gaudisite.nl

## Abstract

Digital engineering is a term that covers a big space full of processes and IT systems. What are the challenges to transition to a smooth digital workflow? This presentation looks at the workflow and ecosystem layers that are involved, in an attempt to map processes, information, and IT-tools.

## Distribution

This article or presentation is written as part of the Gaudí project. The Gaudí project philosophy is to improve by obtaining frequent feedback. Frequent feedback is pursued by an open creation process. This document is published as intermediate or nearly mature version to get feedback. Further distribution is allowed as long as the document remains complete and unchanged.

March 17, 2026  
status: draft  
version: 0.4

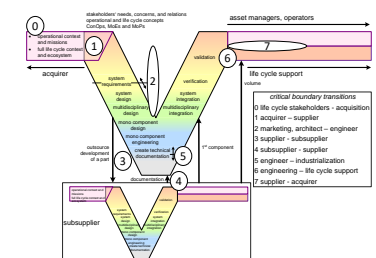

# Figure of Content

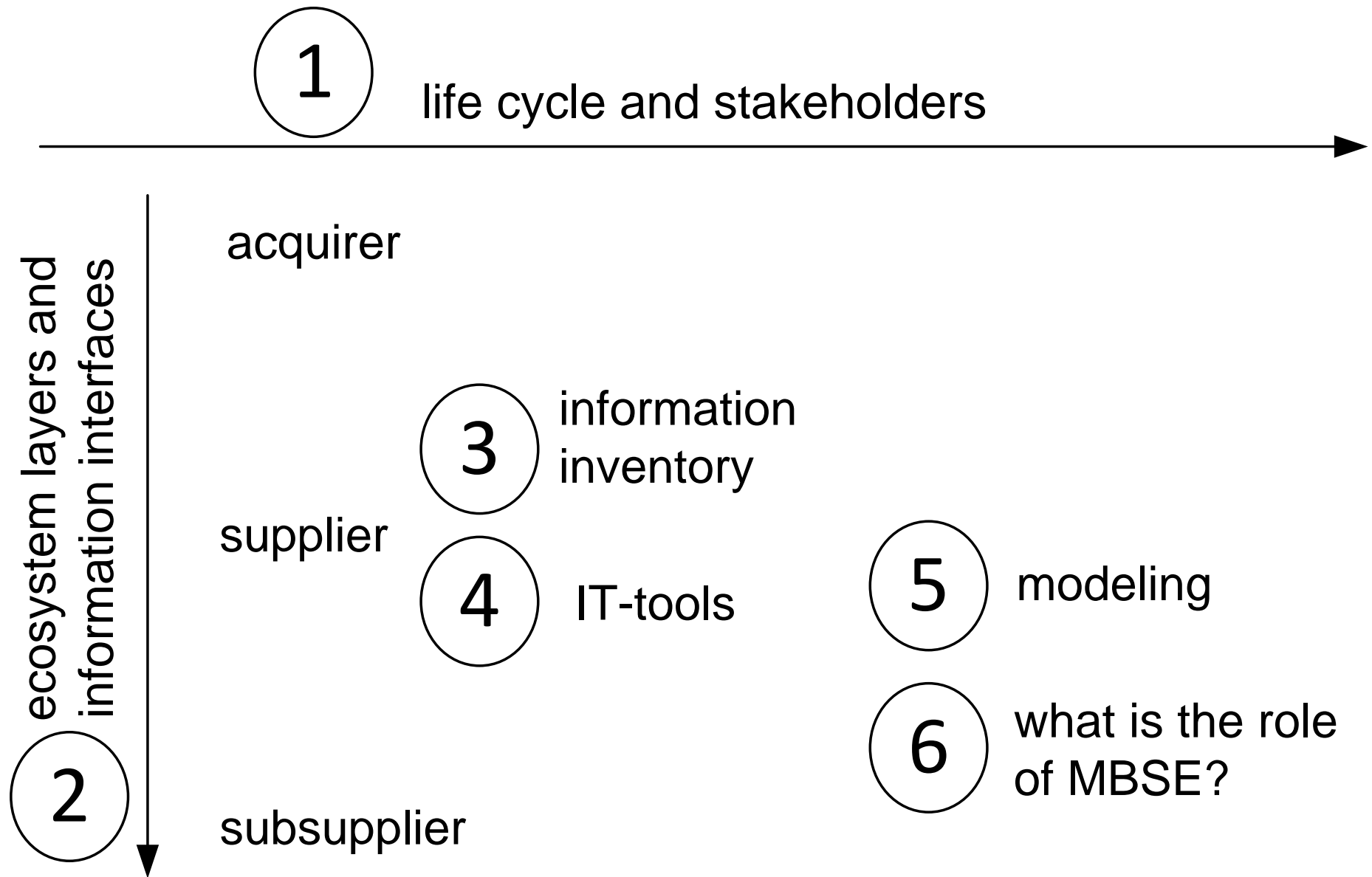

# How to Connect Enterprise and Engineering and Manage Data?

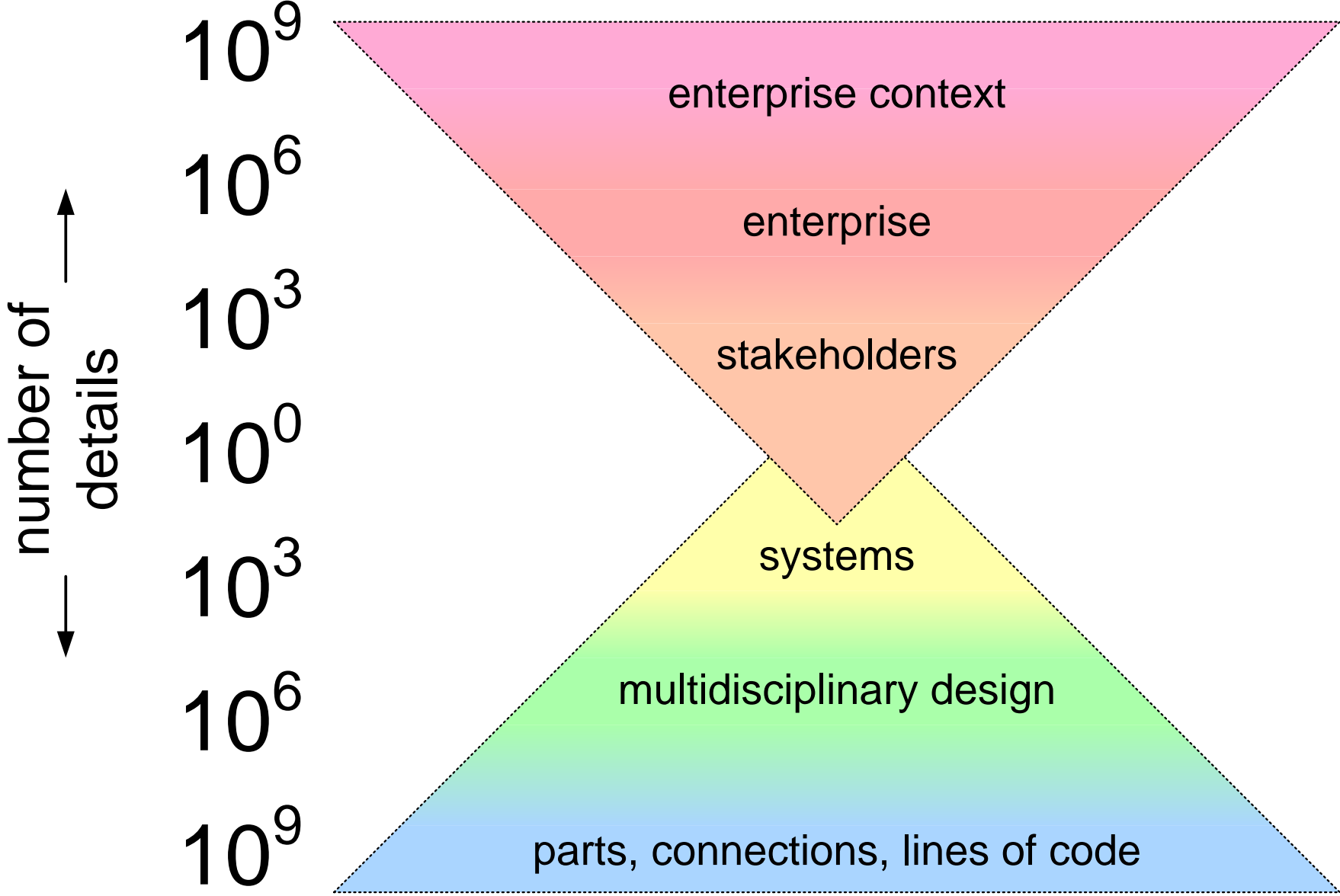

# Life Cycle and Stakeholders

**1**

## life cycle and stakeholders

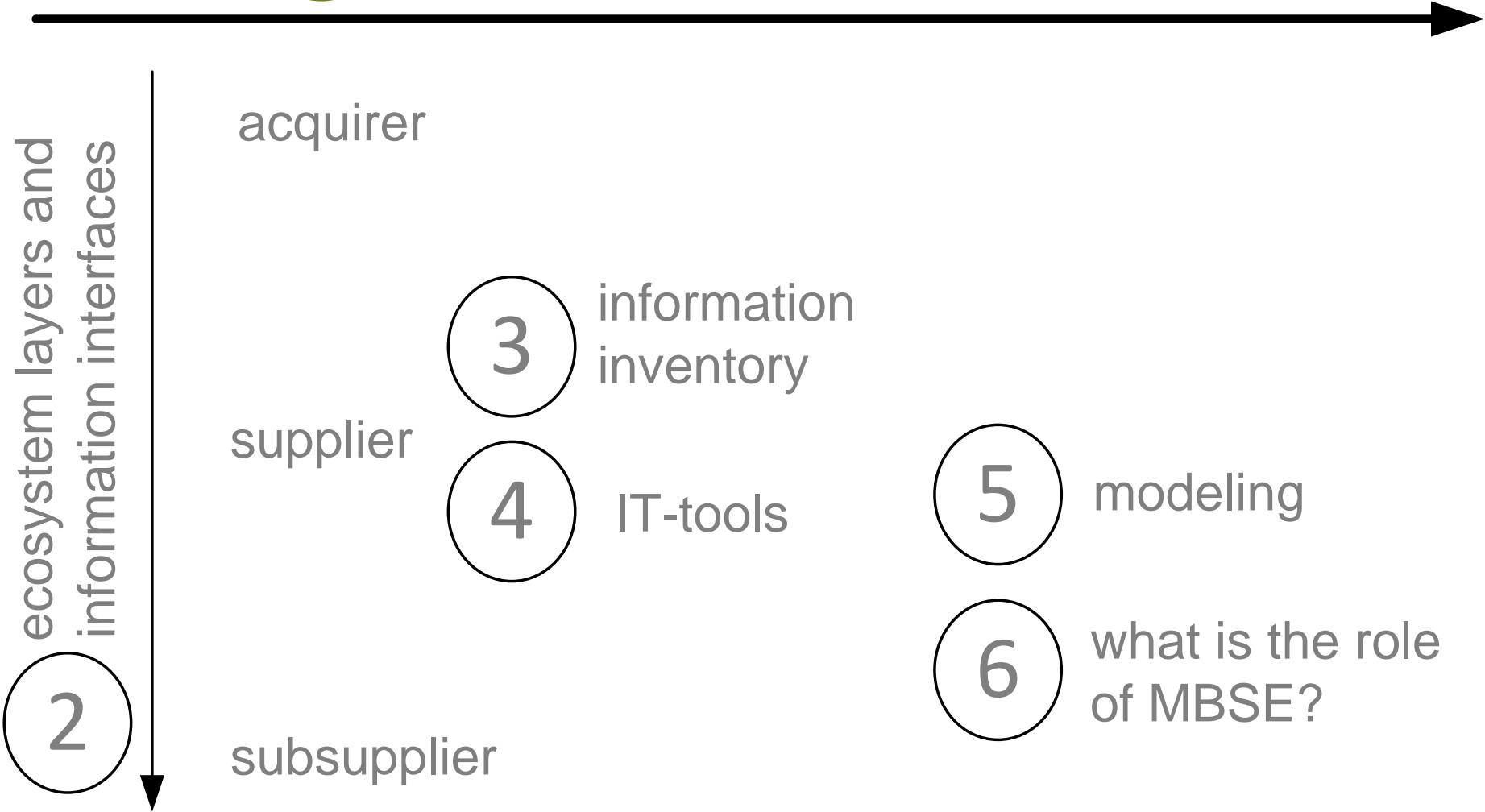

# Input from Life Cycle Support to Development

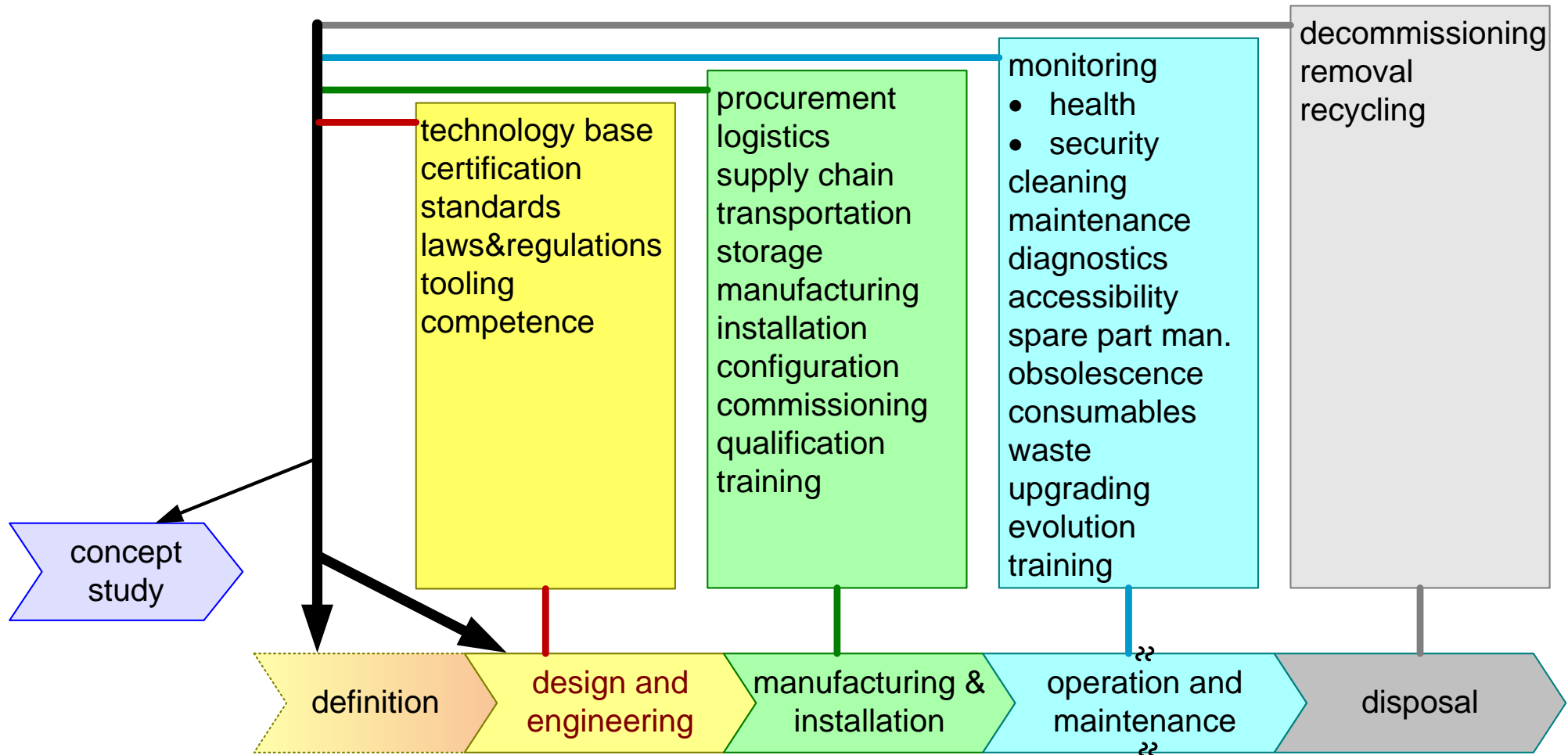

# Engineering produces TPD: the How-to for the Life Cycle

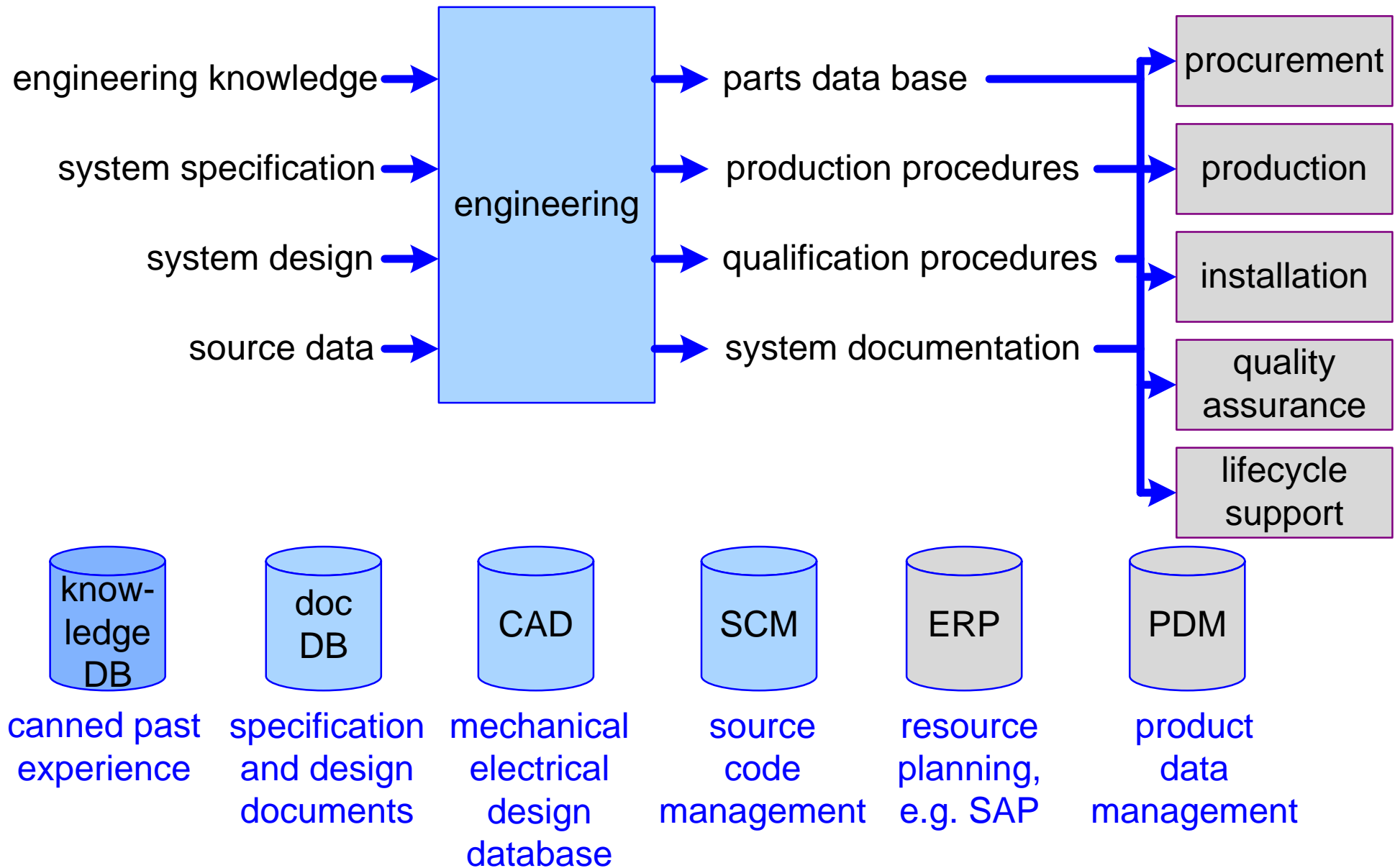

# Example of Production Line, Process Control, Product

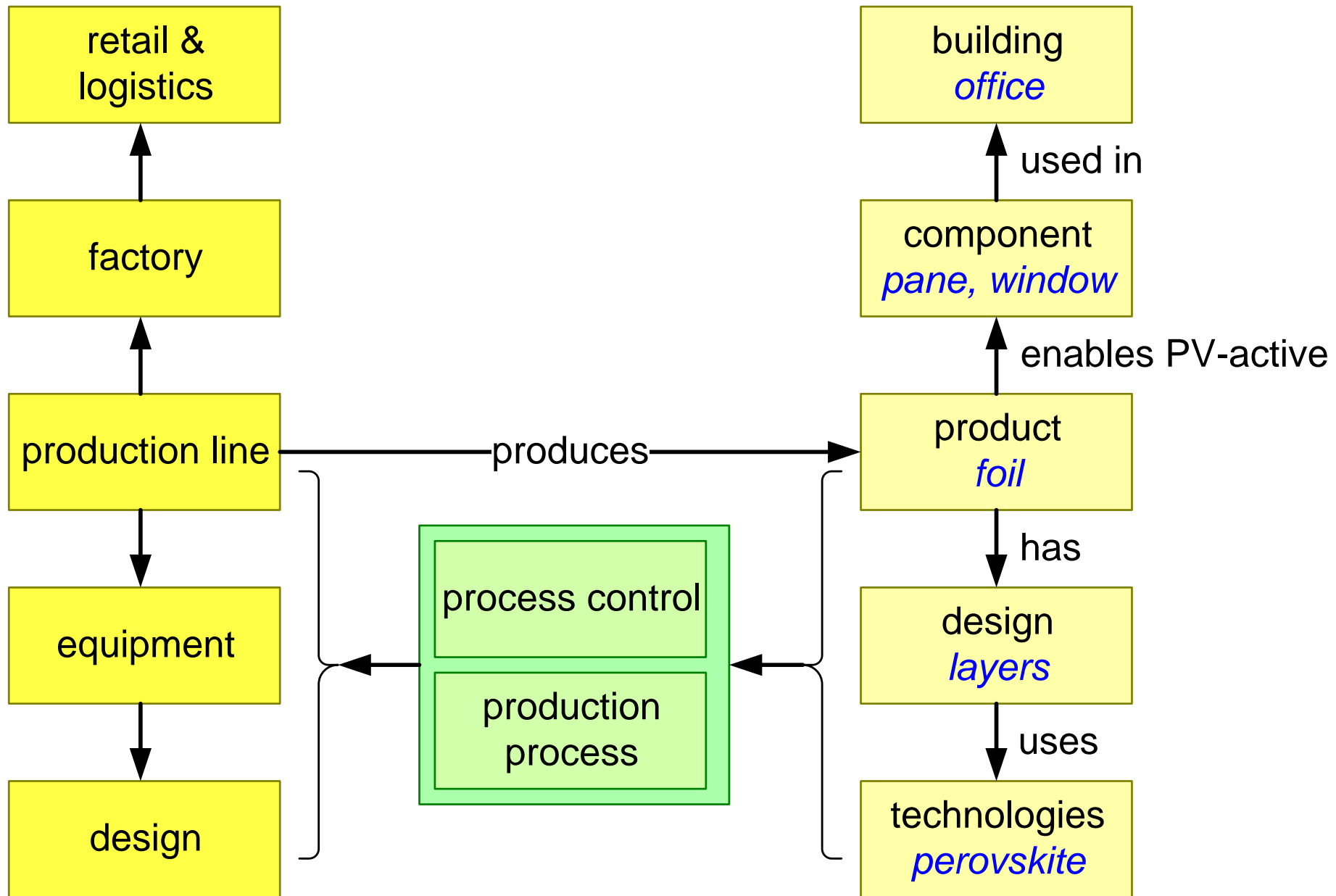

# Flow from Mission to Mono Engineering

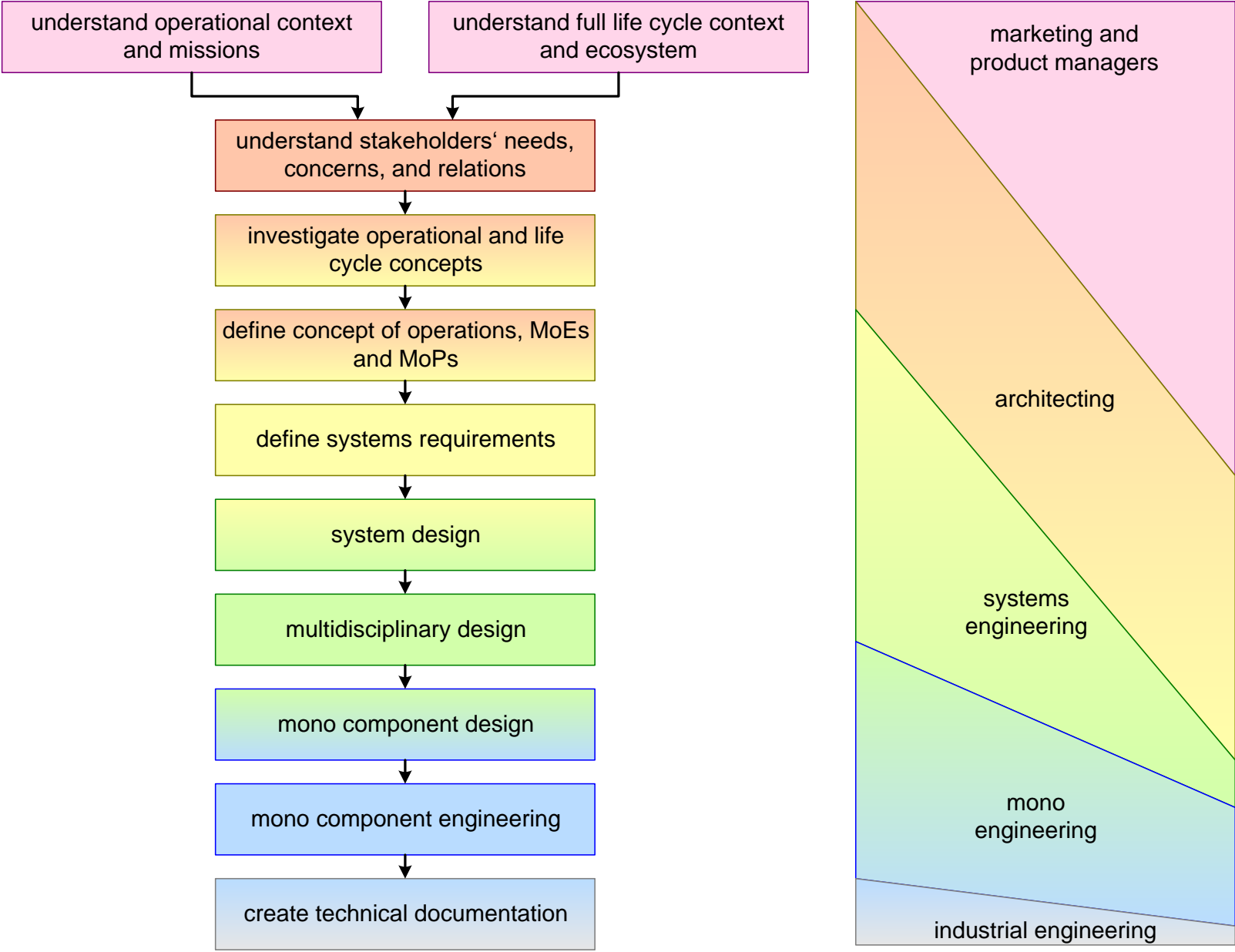

# Iterate over All Development Work Streams

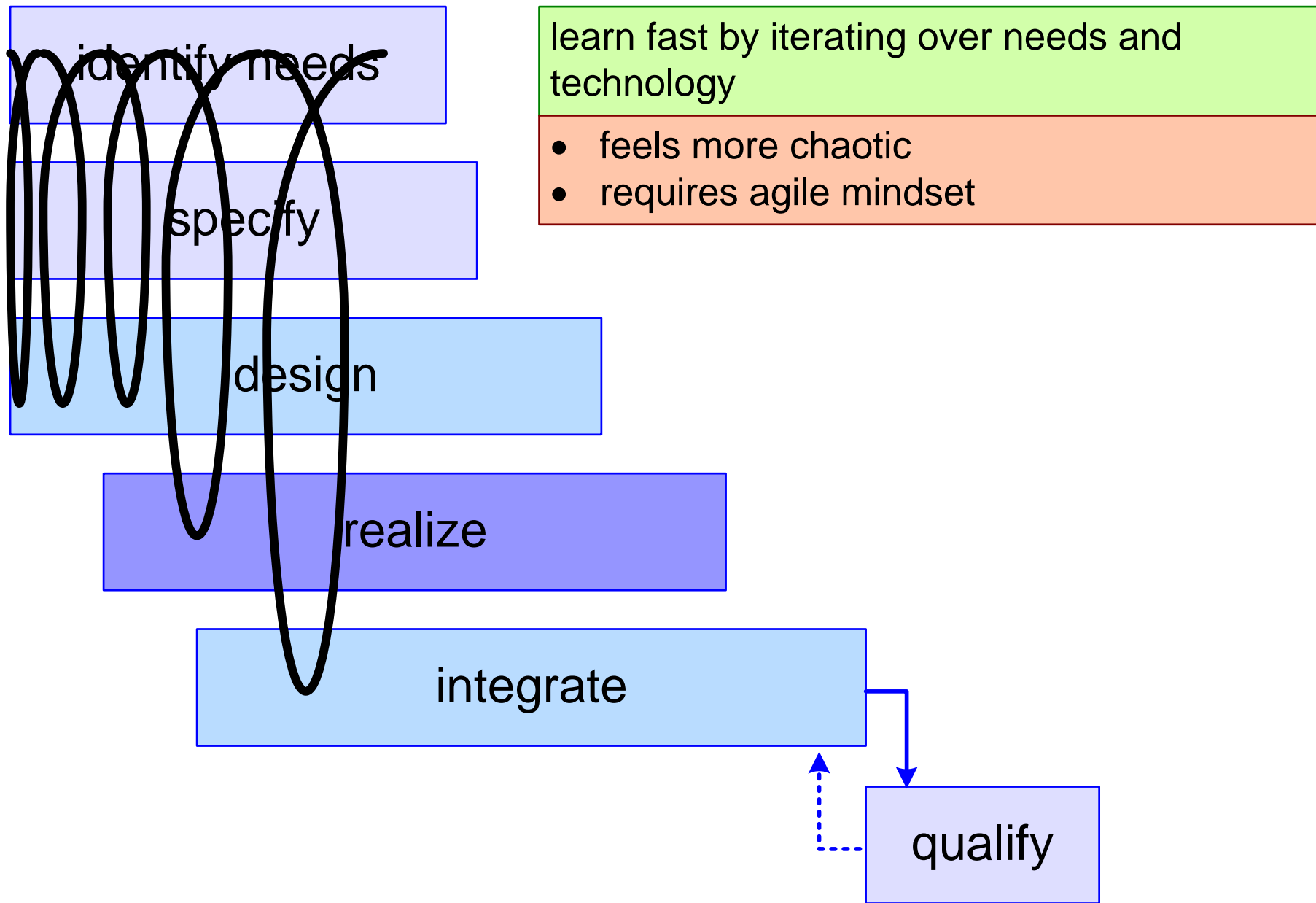

# Ecosystem Layers and Information Interfaces

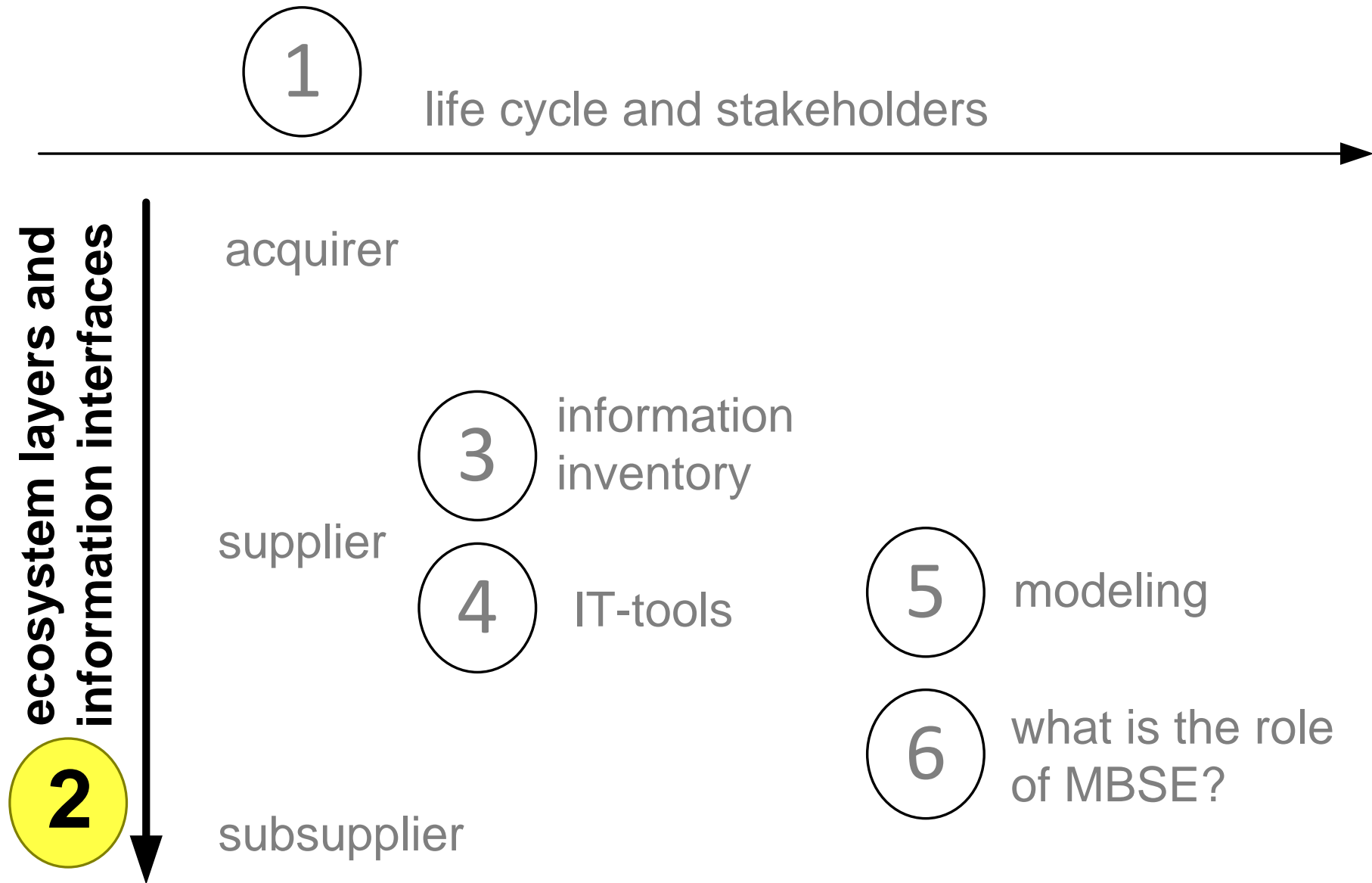

# How Much to Outsource?

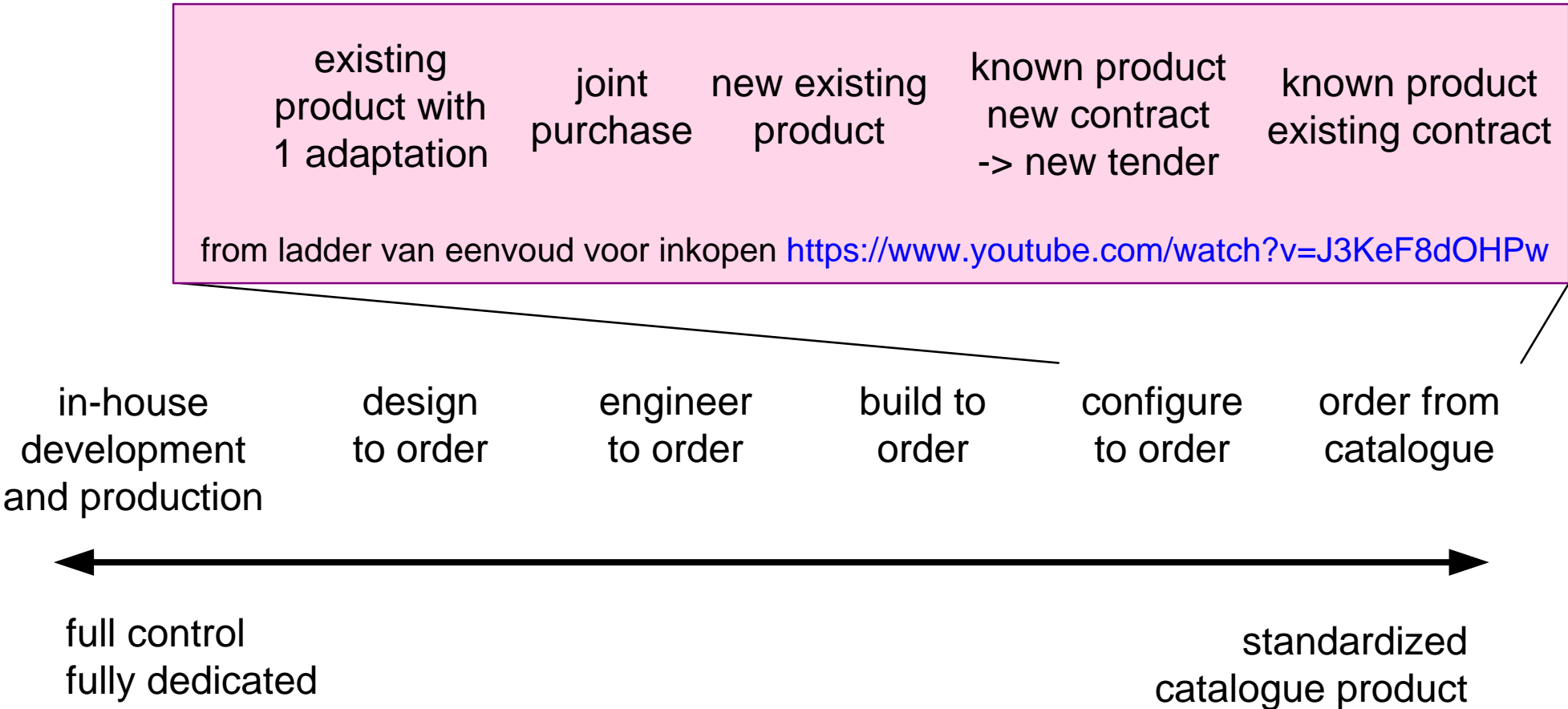

# Information Flows between Organizations

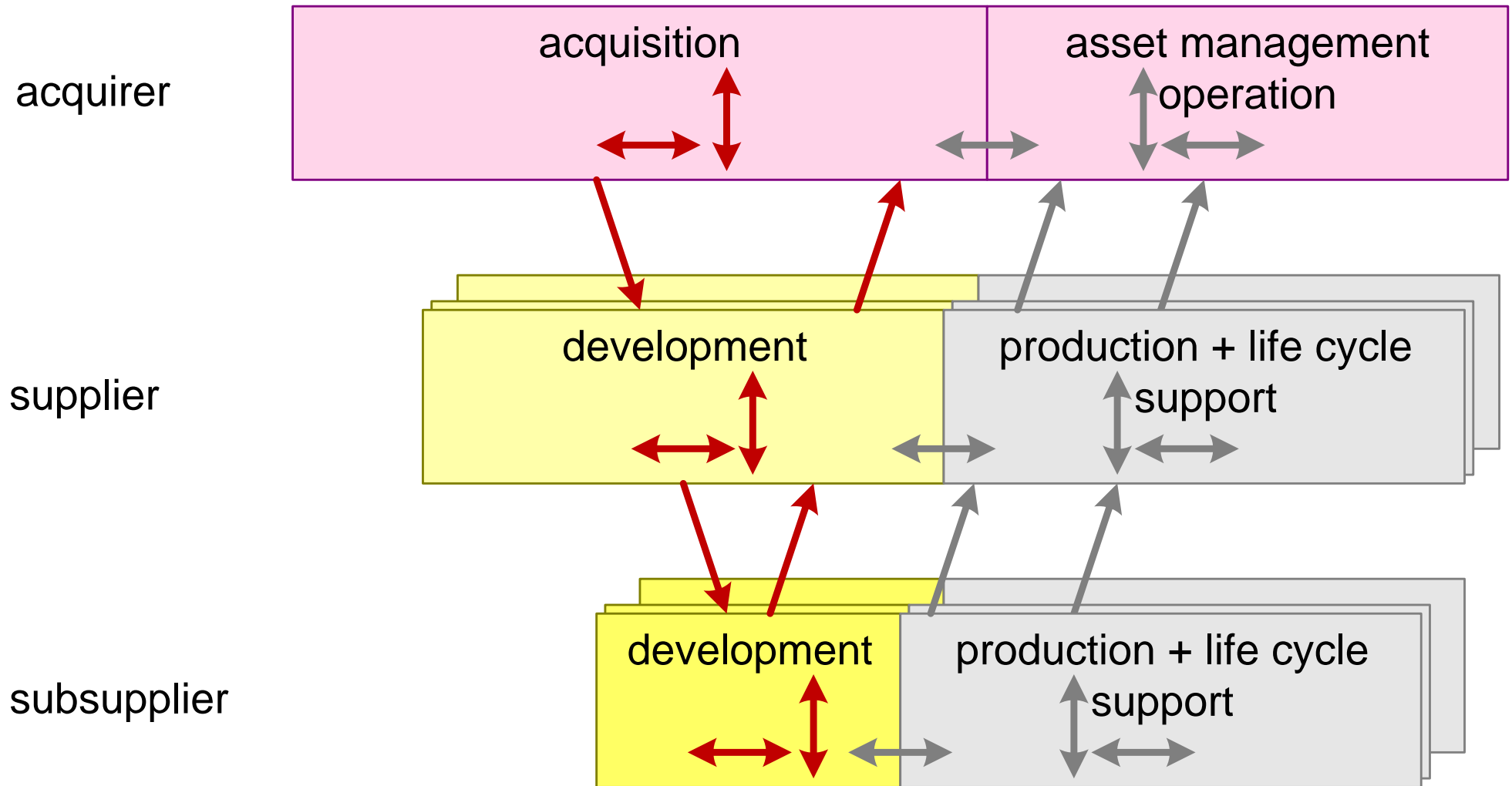

# Critical Boundary Transitions in the V-model

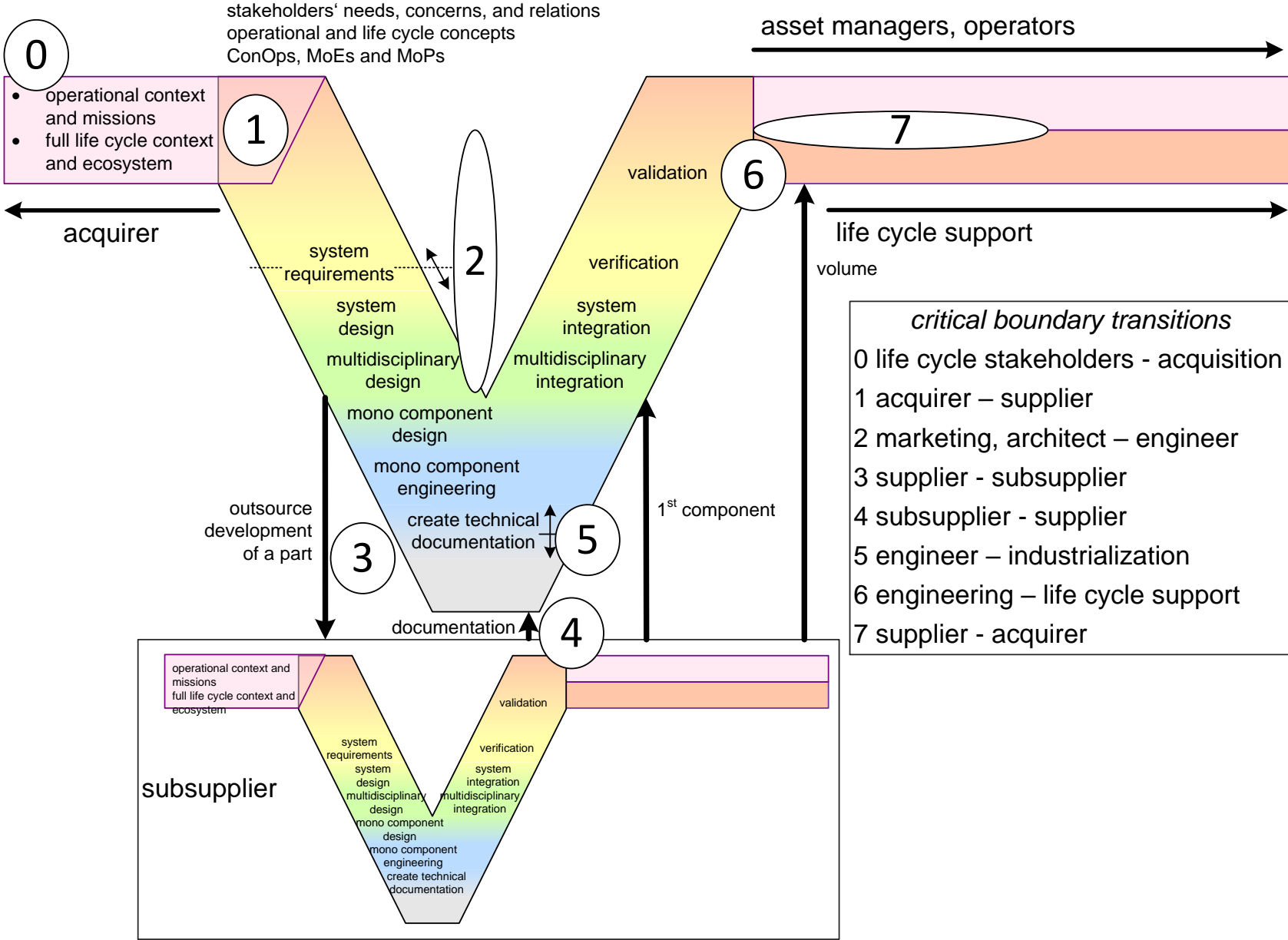

# Project Life Cycles Acquirer and Supplier

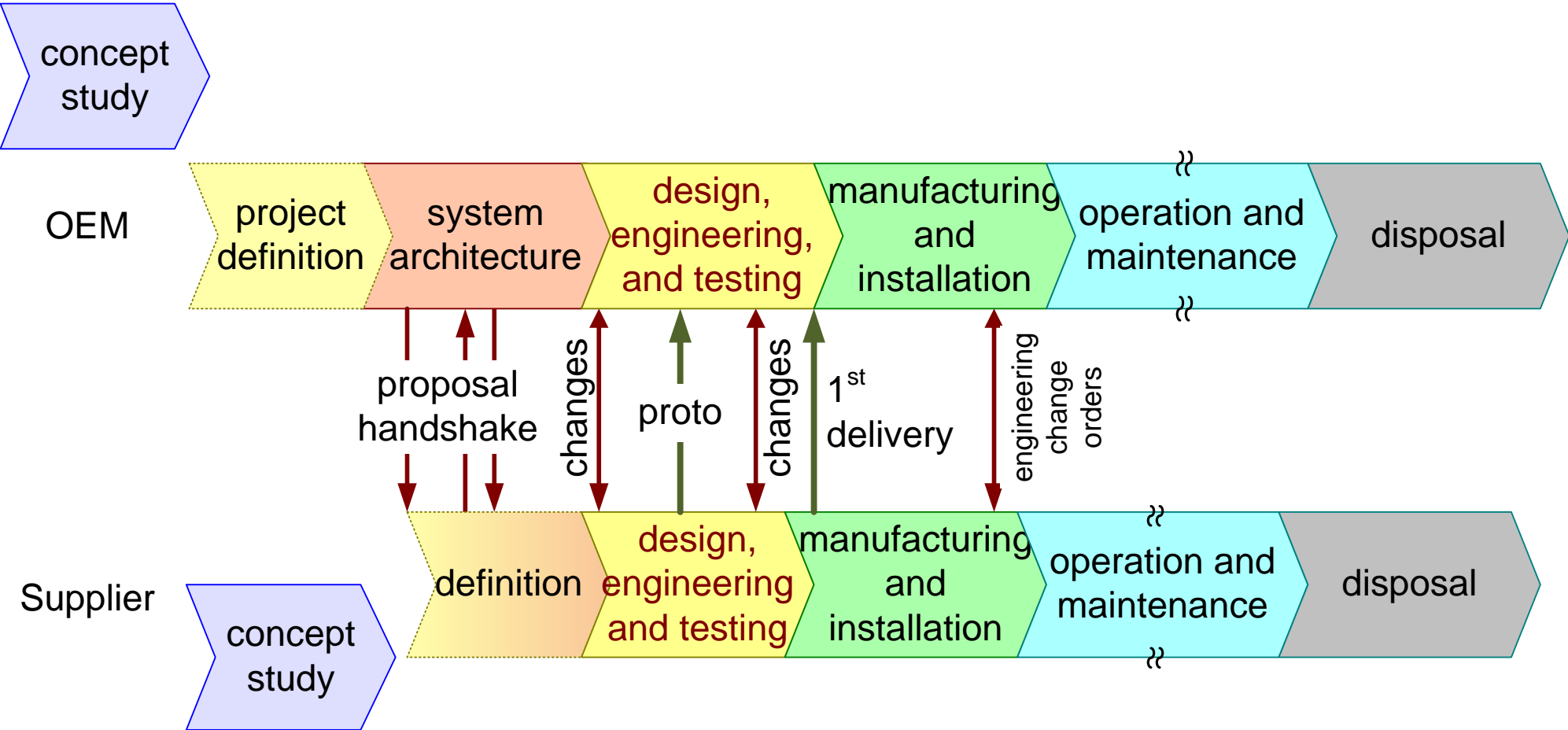

# Interaction Acquirer and Supplier when Outsourcing Design

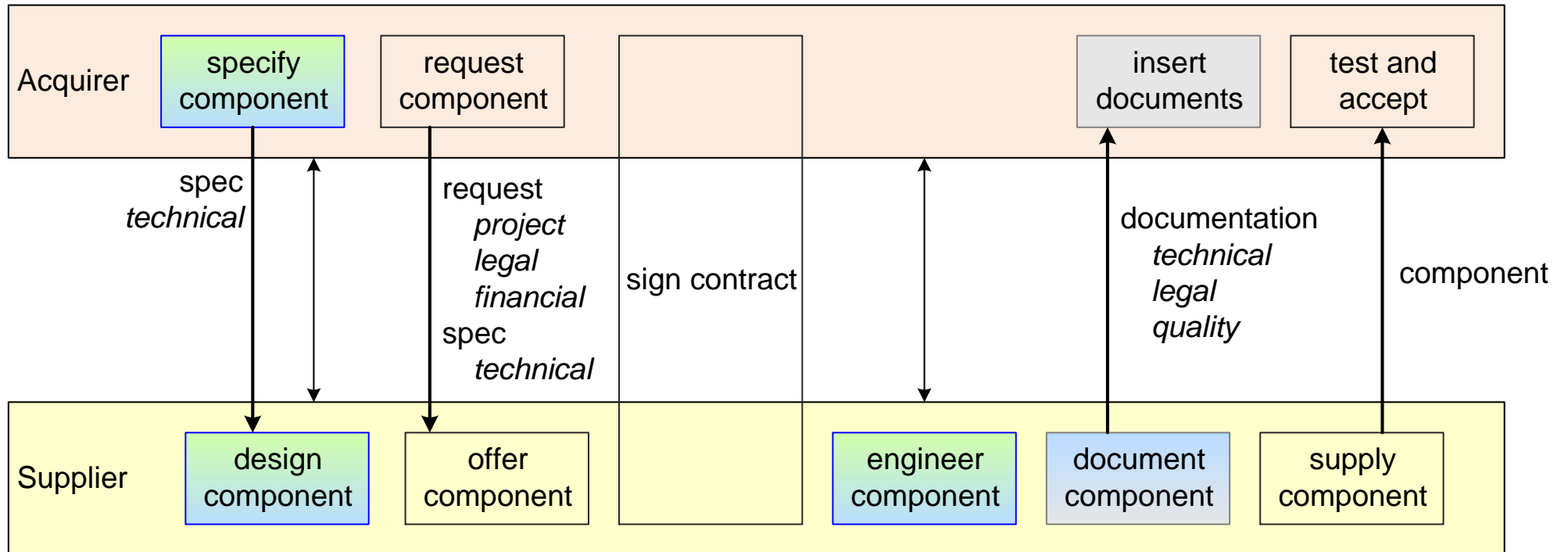

# Information Inventory

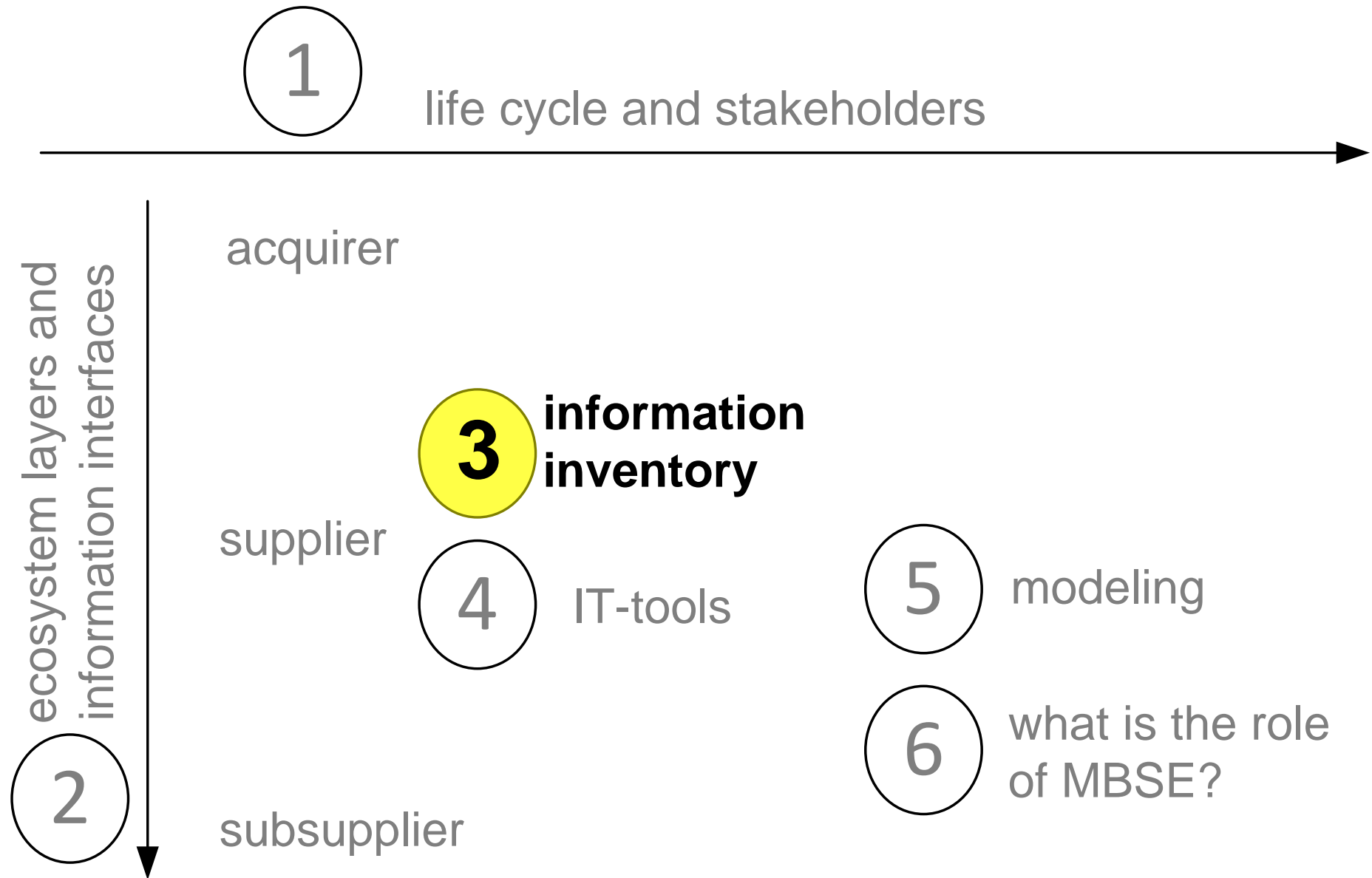

# System Breakdown Hierarchy

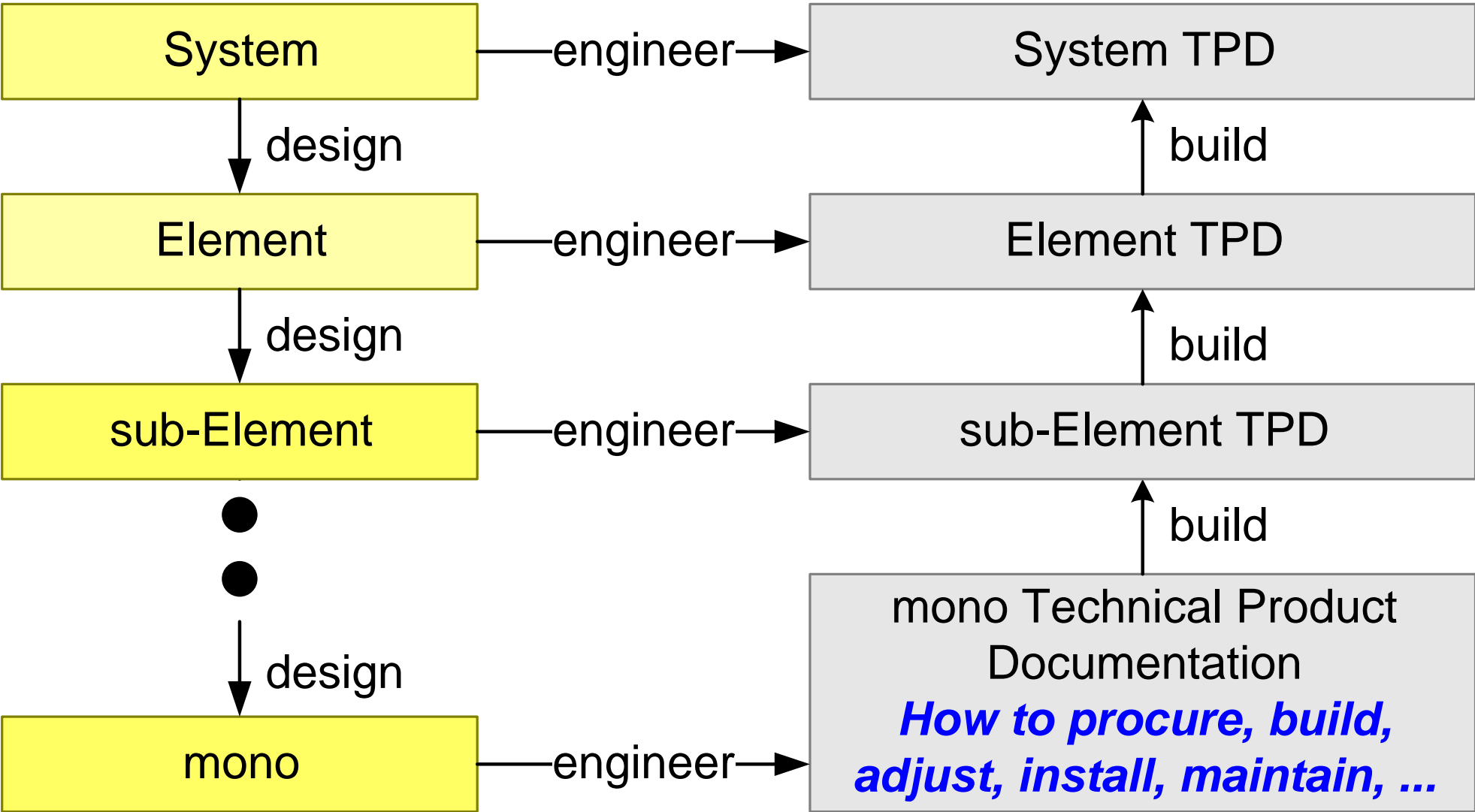

# Specifications per Element

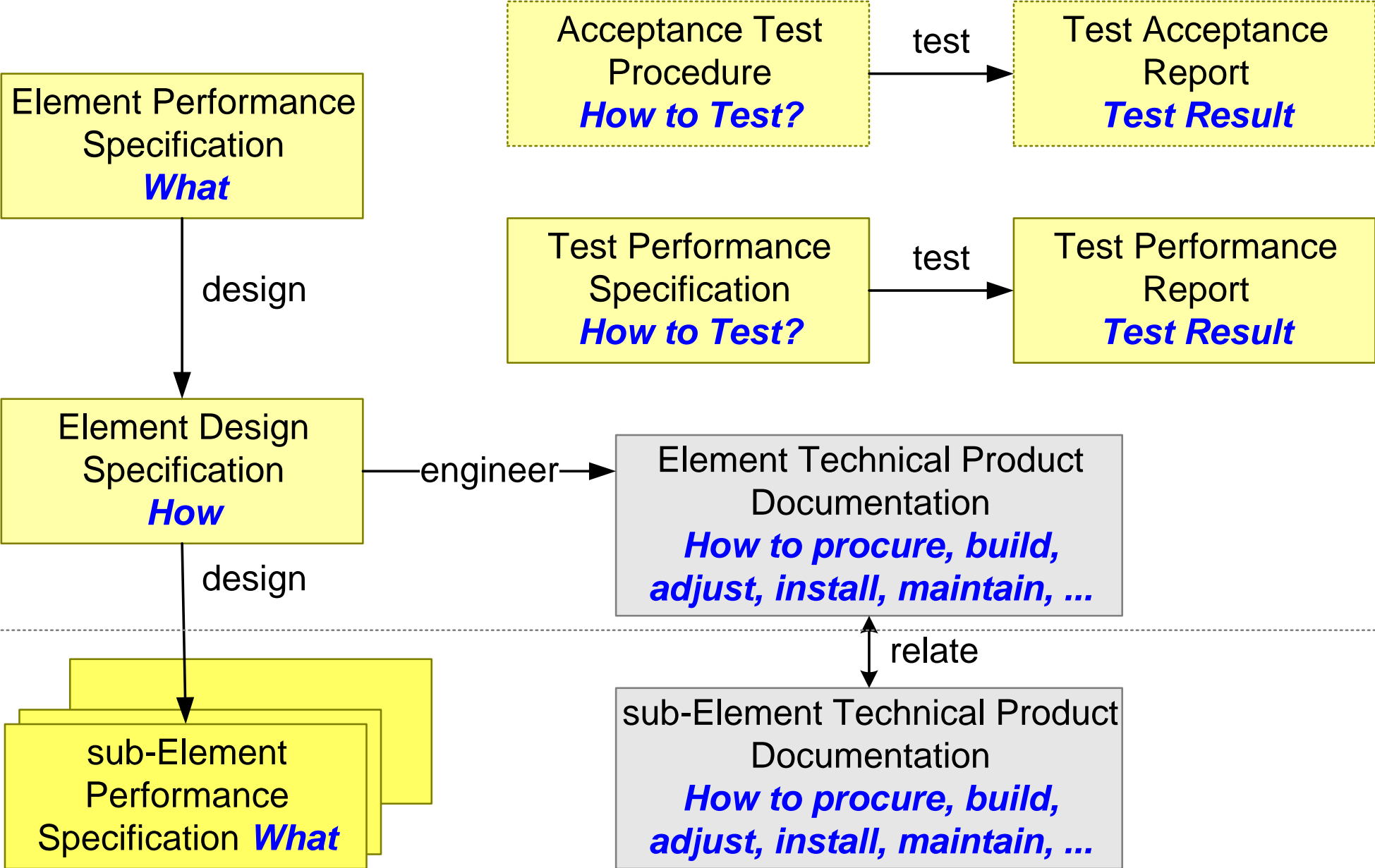

# Performance Specification: What

an Element Performance Specification (EPS) specifies an element as a black box: *What* the element should be able to do, not *How* it should work.  
An EPS specifies the requirements of the element “from the outside”

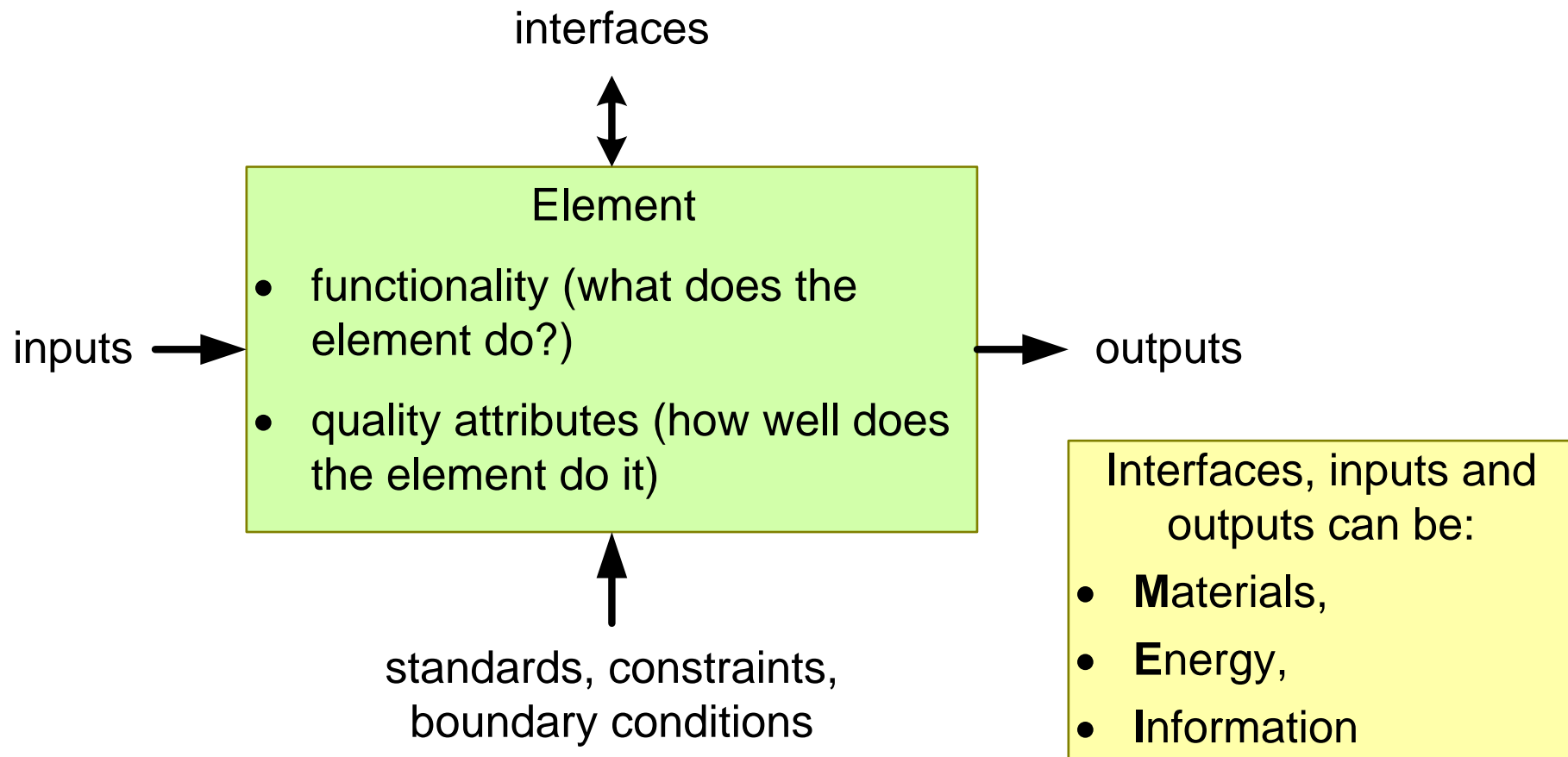

# Design Specification: How

an Element Design Specification (EDS) specifies the design of an element, e.g. the inside of the box: **How** the element will realize the specified functionality and quality attributes.

An EDS specifies the **functional design**, the **breakdown** into sub-elements, the internal **interfaces**, the **allocation** of functions to sub-elements, and the **allocation** of contributions to the **quality attributes** to functions and sub-elements.

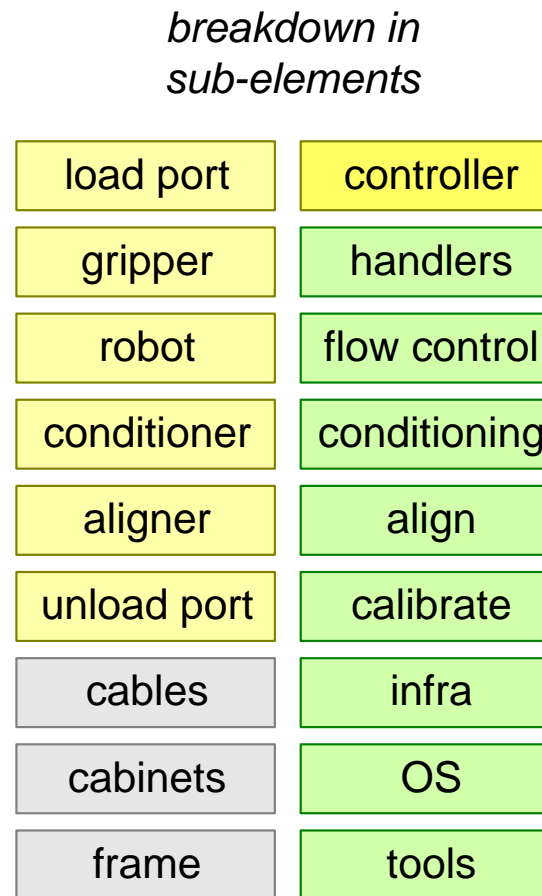
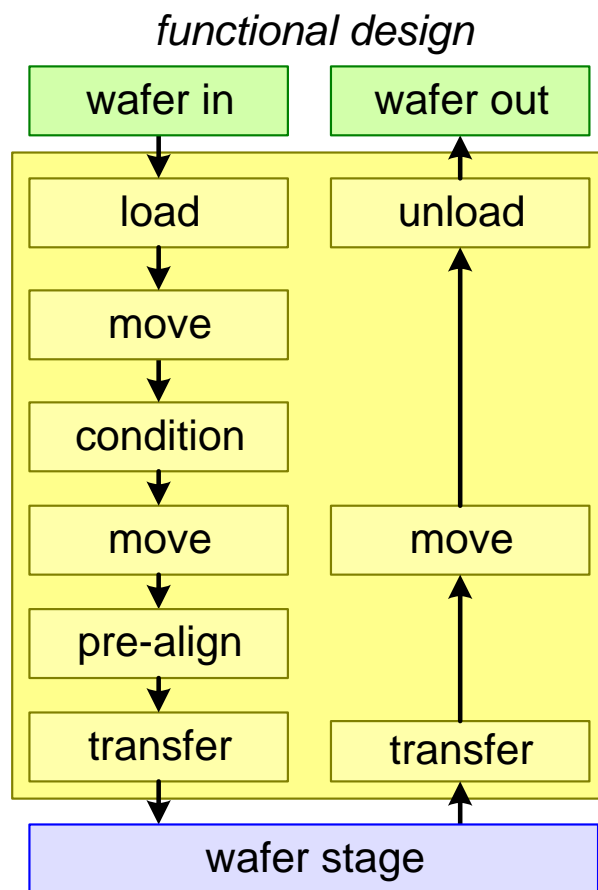

*allocations of quality attributes to functions and sub-elements*

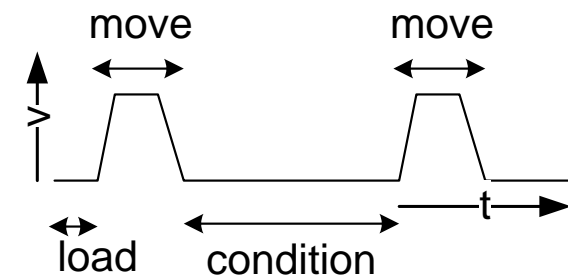

# Product Structure and Documentation

The **Product Structure** prescribes the **parts hierarchy**. Each part in the hierarchy has associated **documentation** and **information** for the entire **life cycle**.

The Product Structure and associated documentation help the organization to **manage** all processes from creation to decommissioning and recycling, via **ERP**, **PDM**, **PLM** etc. systems.

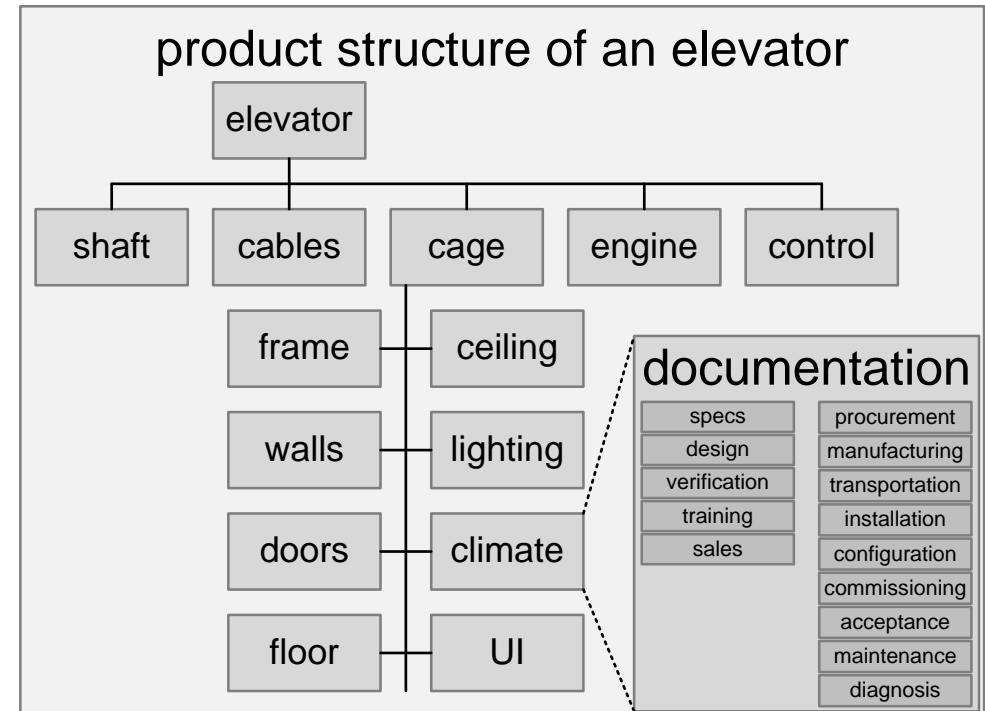

# The Digital Mono-Engineering Environments

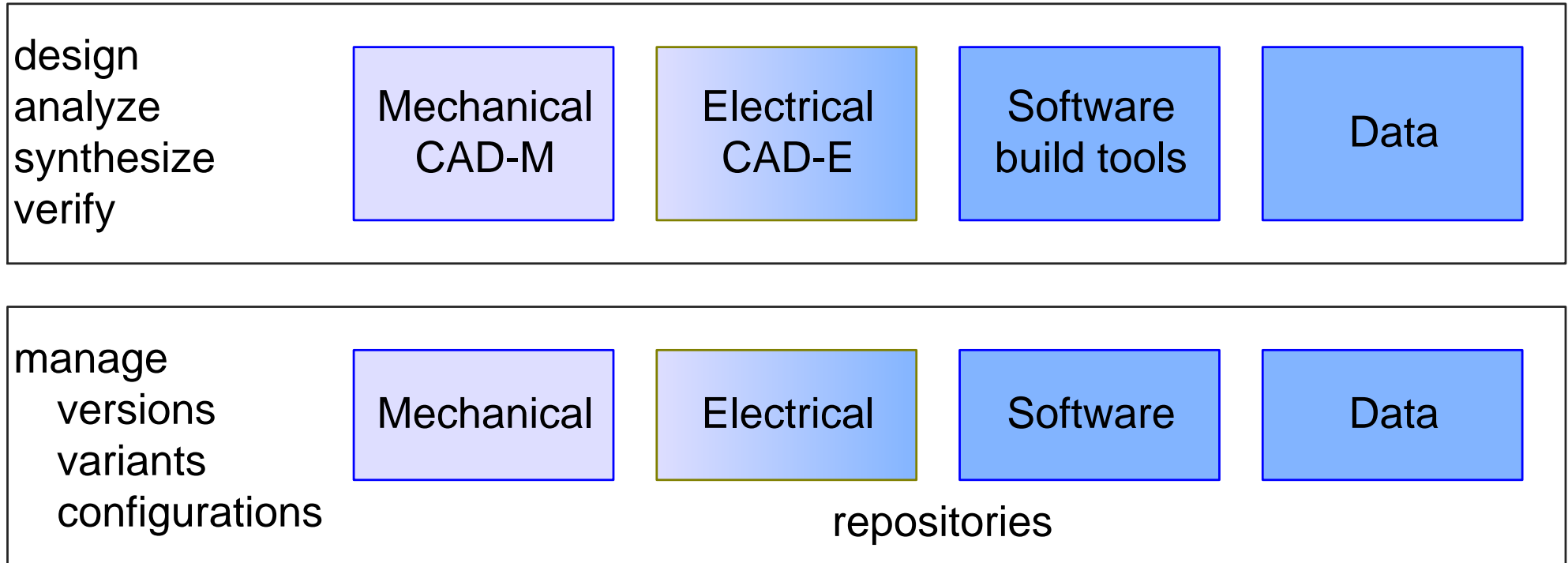

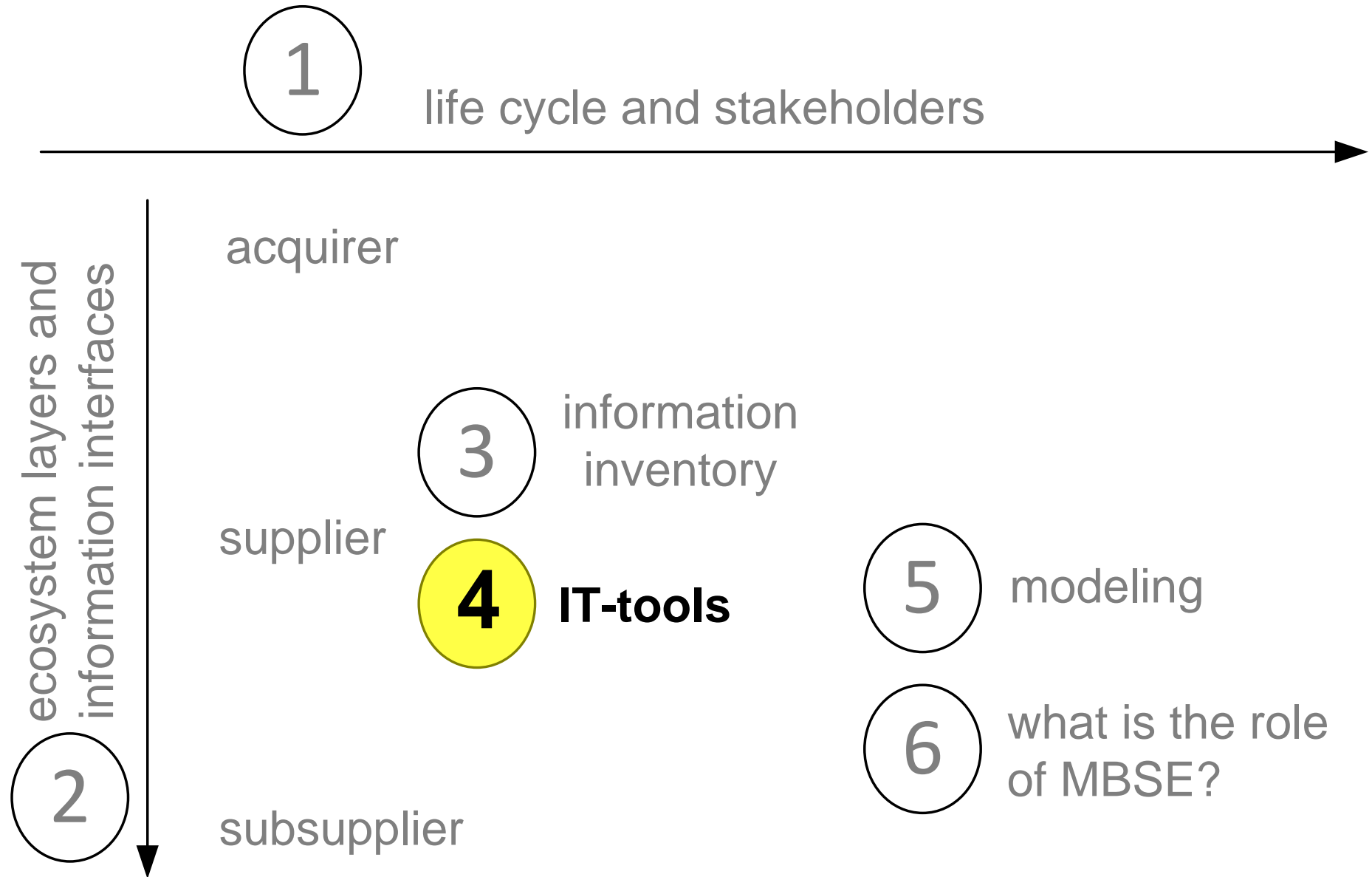

# IT-Tools a Supplier is Using

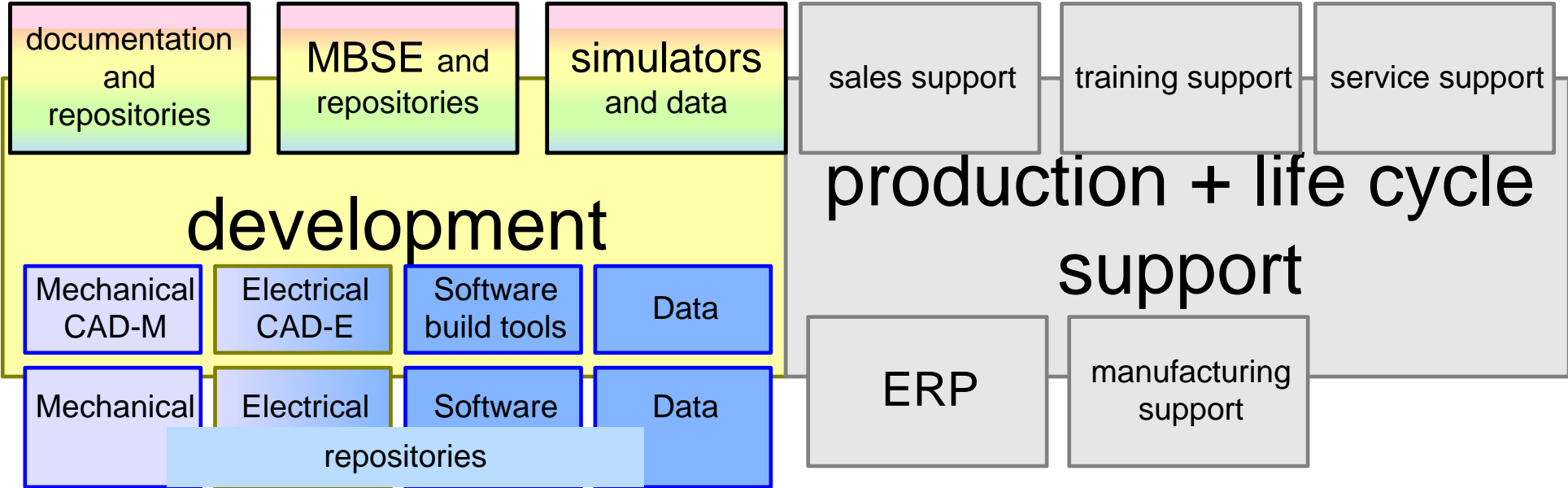

# IT-Tools across Layers when Outsourcing Design

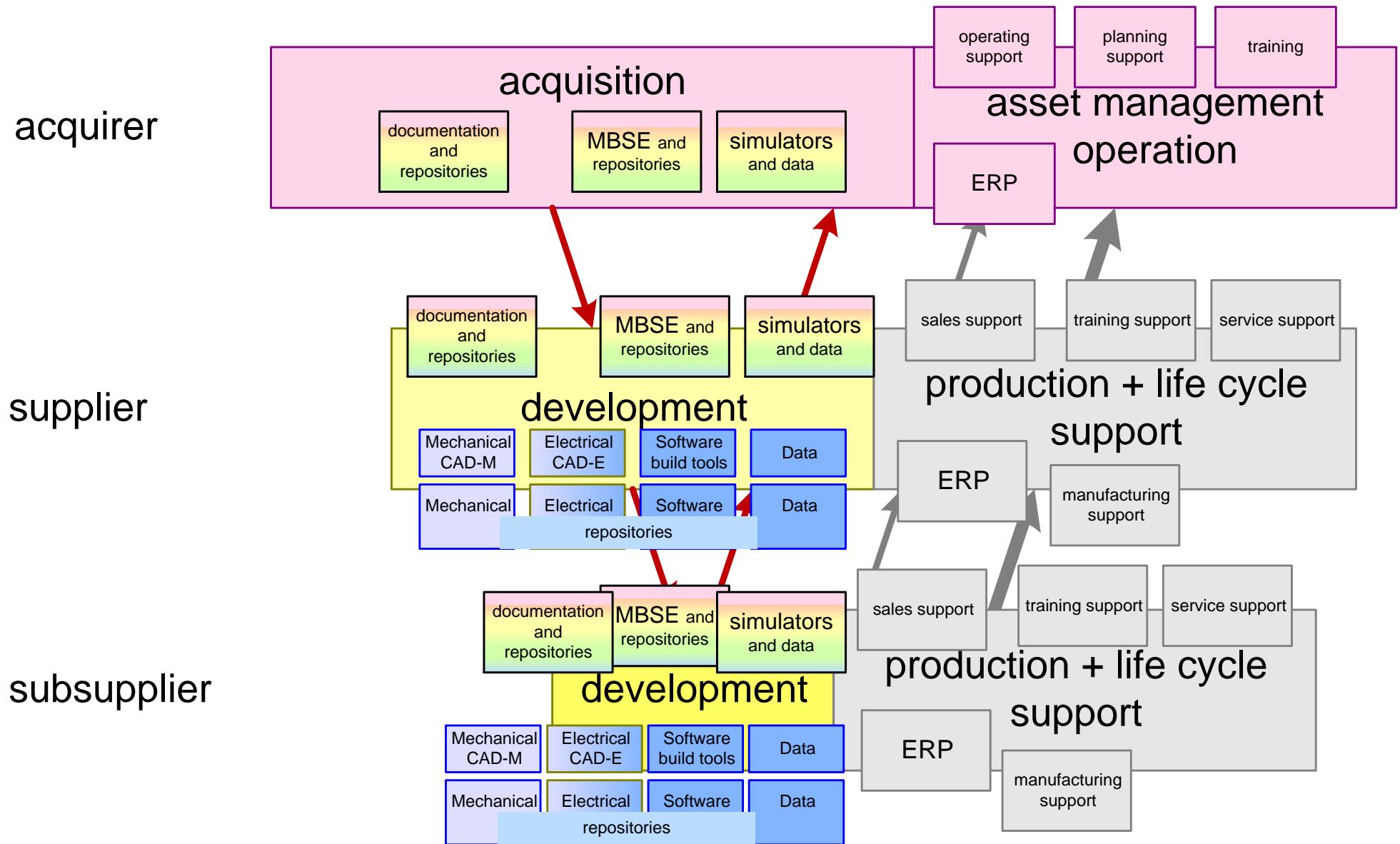

# Modeling

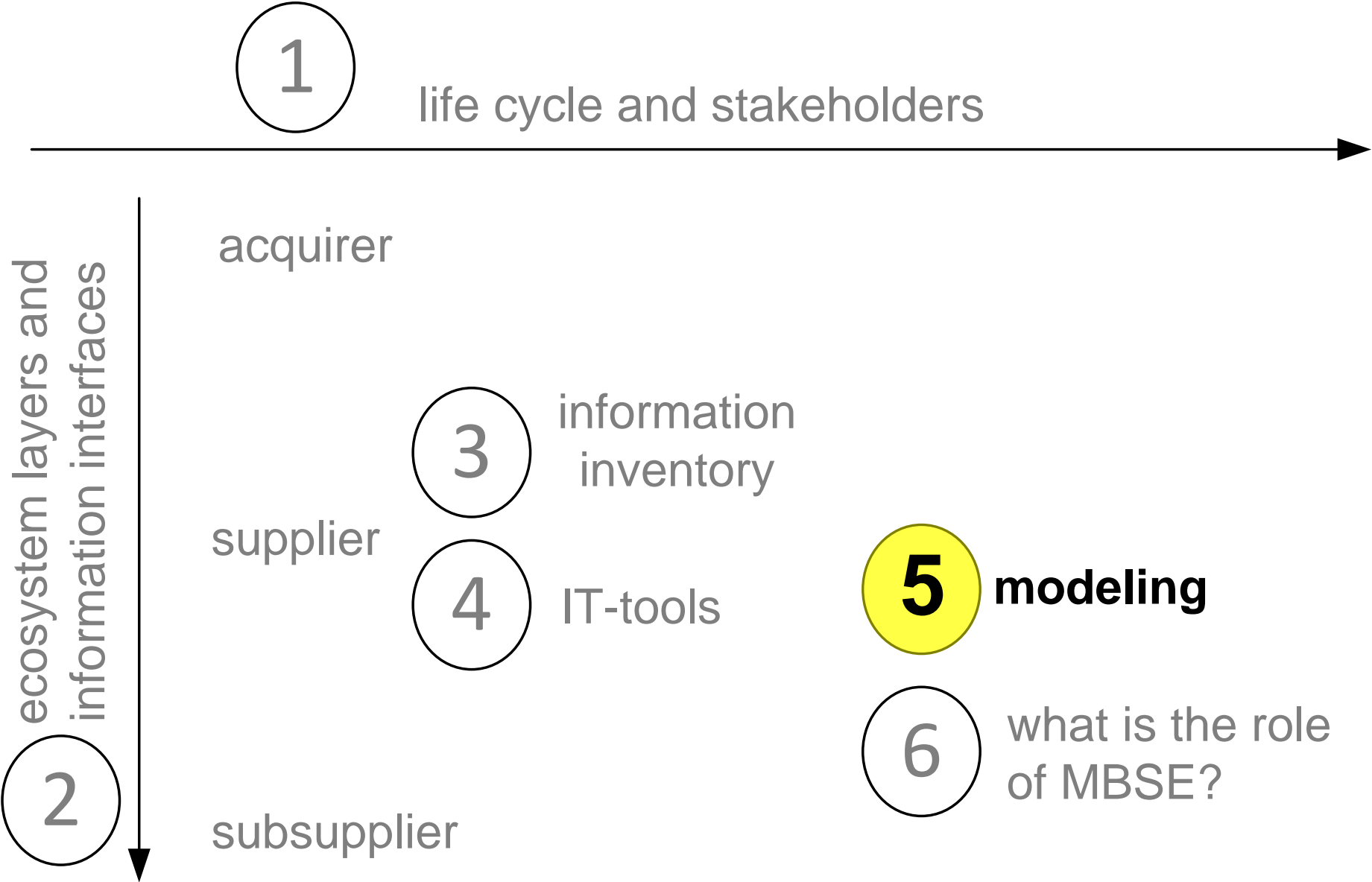

A **model** is  
a **simplified** representation of  
*part* of the **real world** used for:  
  
communication, documentation  
analysis, simulation,  
decision making, verification

# The Modeling Space

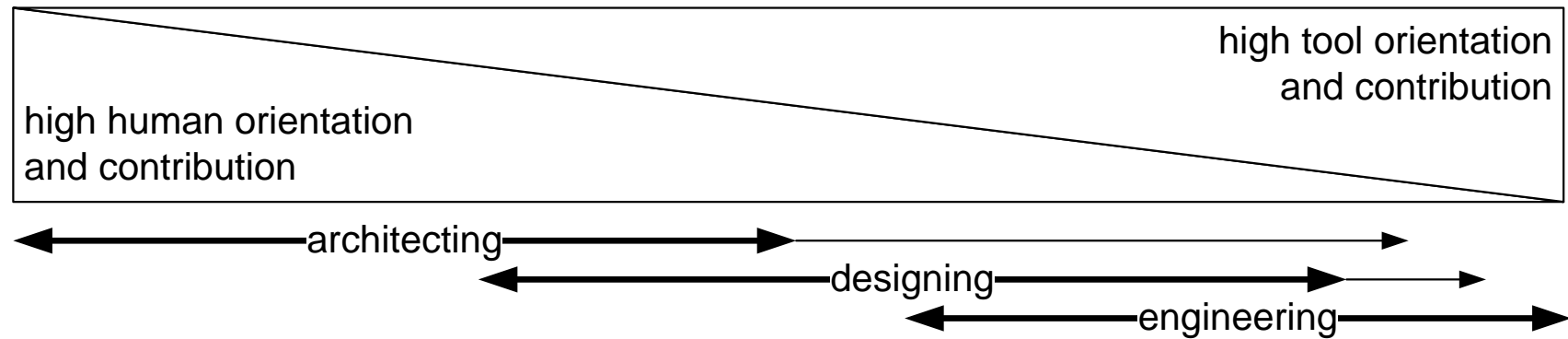

	shared understanding, communication, reasoning, decision making	supporting process and organization		
purpose		problem and solution space exploration	problem and solution space analysis	managing tracing qualifying
fidelity	very limited sufficient for decisions	increasing over time and phase →		
degree of formality	very limited interaction is crucial	increasing over time and phase →		
executable	fast prototyping: executable	problem and solution space: executable	managing and tracing: navigatable and analyzable qualifying: executable	

# Map of Modeling Types

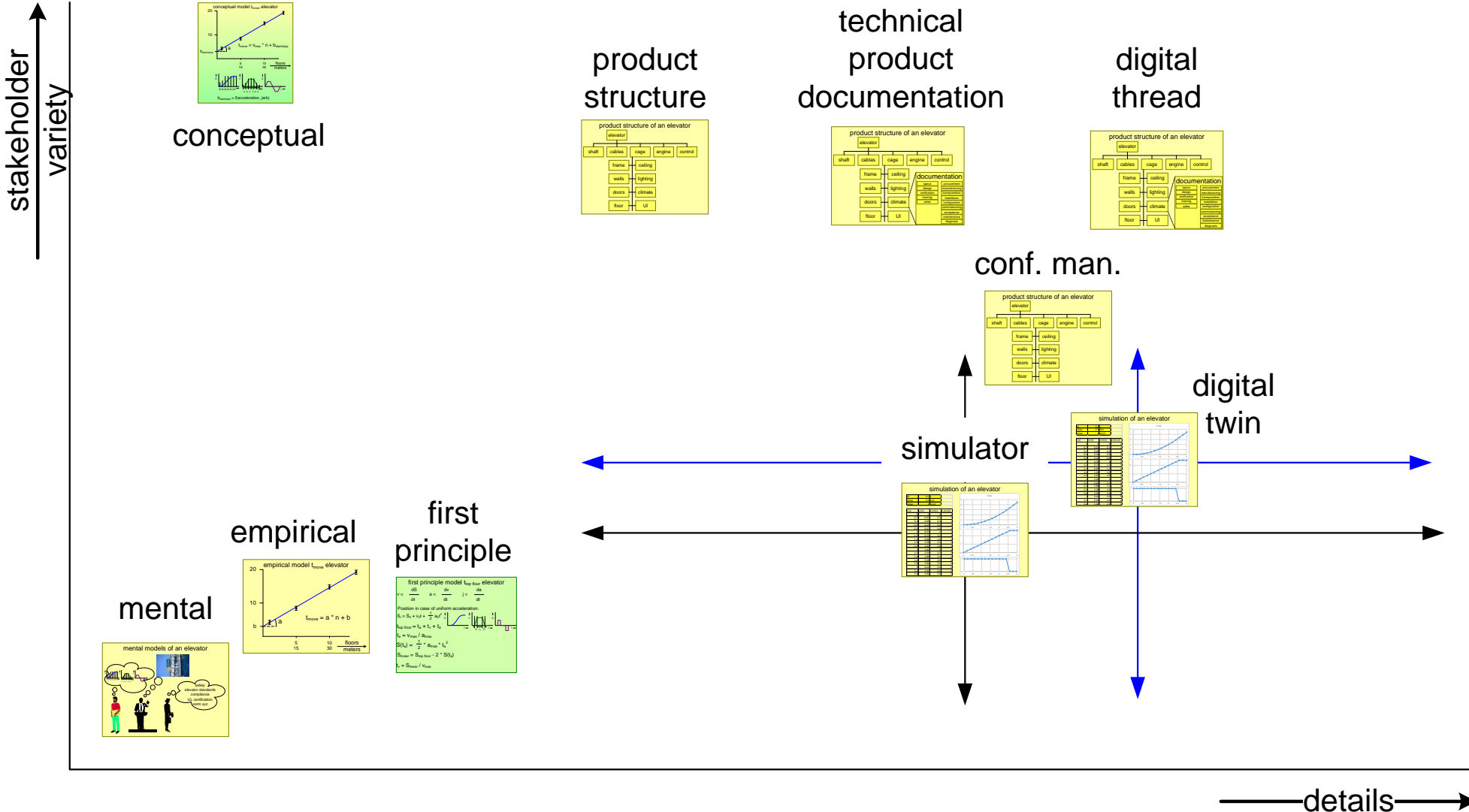

# Conceptualization Reduces 3 to 5 Orders of Magnitude

data increase  
 implementation \*10..100  
 conceptual dynamics  
 -> full space \* 100..1000

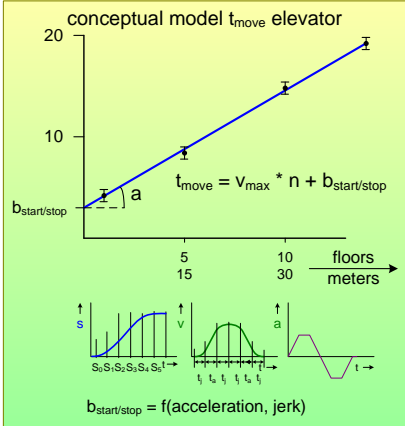
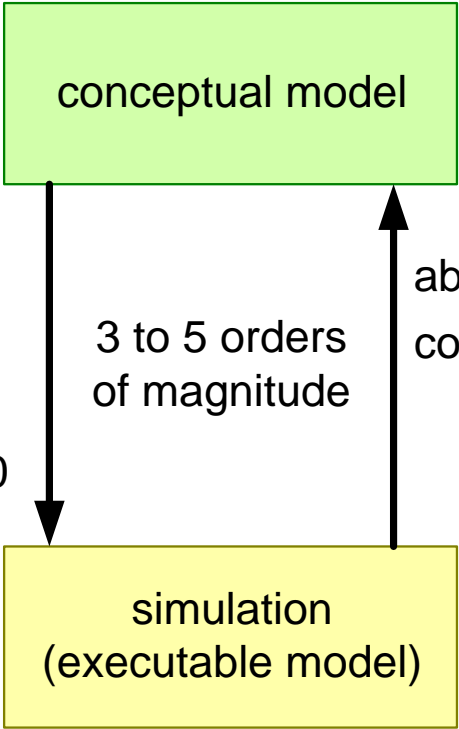

S, a, v, j  
 $t_{\text{floor}}$ ,  $t_v$ ,  $t_a$

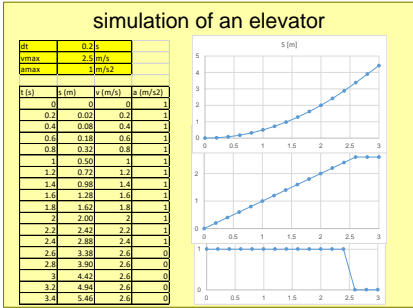

# What is the Role of MBSE?

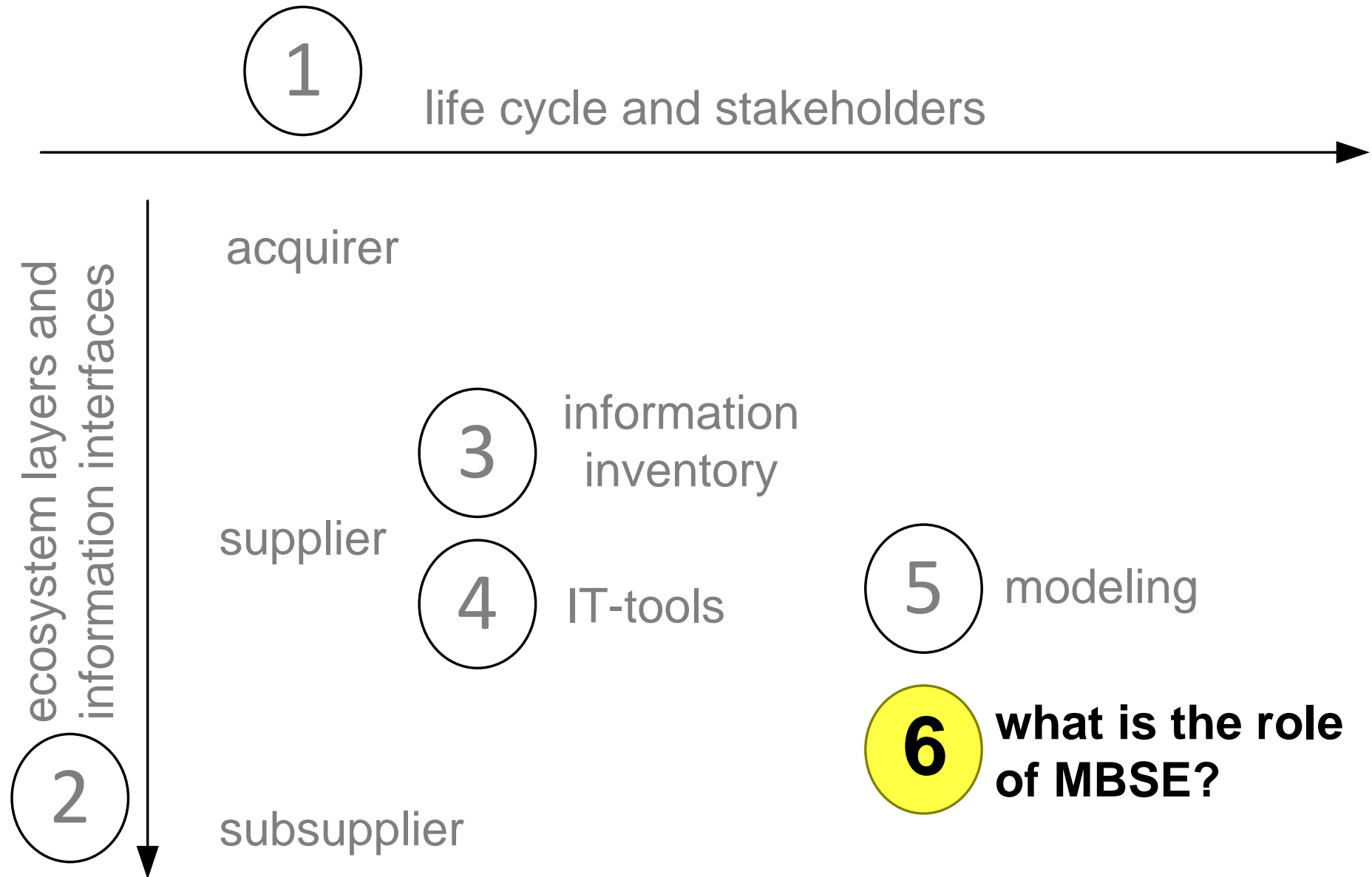

# What Role Does MBSE Play?

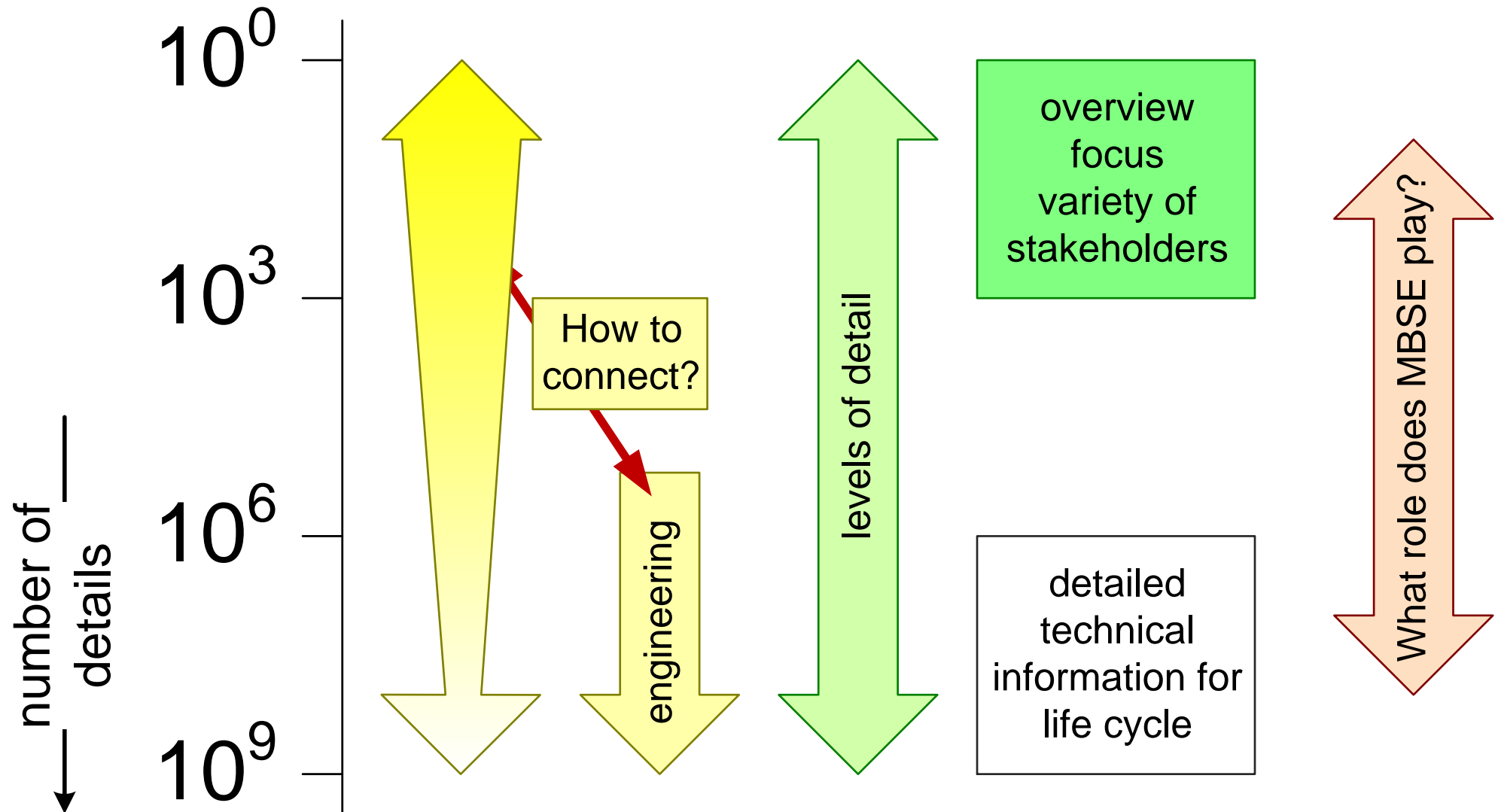

# Complexity challenges require architecting and engineering

## *common problems*

- the project is **inefficient**
  - needs too many resources
- suffers from **delays, cost overruns**
  - late design changes
  - surprises during integration or deployment
- many “**manual**” transitions and operations
  - handovers increase risk
- long system **lifetime**
  - obsolescence
  - changing context
- **organizational complexity**
  - ecosystems, supply chains

## *proposed architecting solutions*

- **overview**
  - compact information, A4, A3
  - connecting the dots
  - covering the dynamics
- **focus**
  - emphasis on key drivers, performance parameters and design decisions
- support for **communication** between **heterogeneous stakeholders**
  - visualization and conceptualization

## *proposed engineering solutions*

- process and tooling support
- information models for interoperability
- “MBSE” + wide variety of IT tools

# What is the real MBSE objective?

---

- to support **reuse** or a platform based product strategy
  - to configure, generate, compose, validate
- to **automate** or generate
  - **tests, simulations**
- to **trace** needs, requirements, or quality attributes throughout the design and engineering
  - especially regulated qualities like **safety**
- to function as **knowledge base** for development and engineering
- to **access component-data** based on the field configuration (digital shadow)
- to populate and update **PLM** systems, e.g. ERP (digital thread)