

Ecosystem Examples

by *Gerrit Muller* USN-SE

e-mail: gaudisite@gmail.com

www.gaudisite.nl

Abstract

This is a collection of examples of ecosystems.

Distribution

This article or presentation is written as part of the Gaudí project. The Gaudí project philosophy is to improve by obtaining frequent feedback. Frequent feedback is pursued by an open creation process. This document is published as intermediate or nearly mature version to get feedback. Further distribution is allowed as long as the document remains complete and unchanged.

June 7, 2026
status: draft
version: 0.2

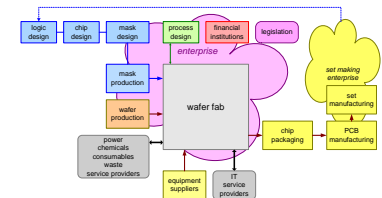

Gerrit's Relevant Experiences

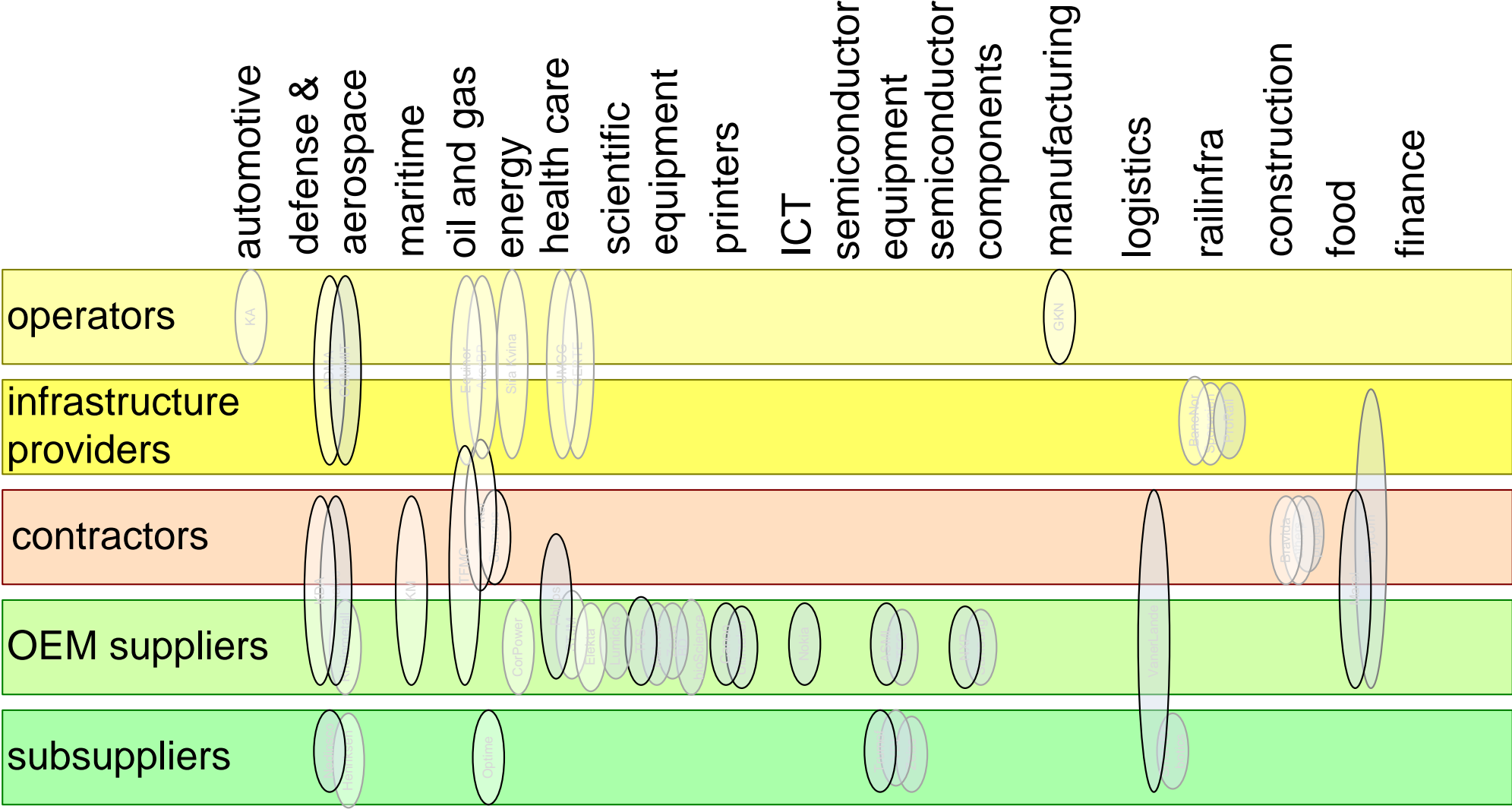

Highly Simplified Presentation of a National Defense Ecosystem

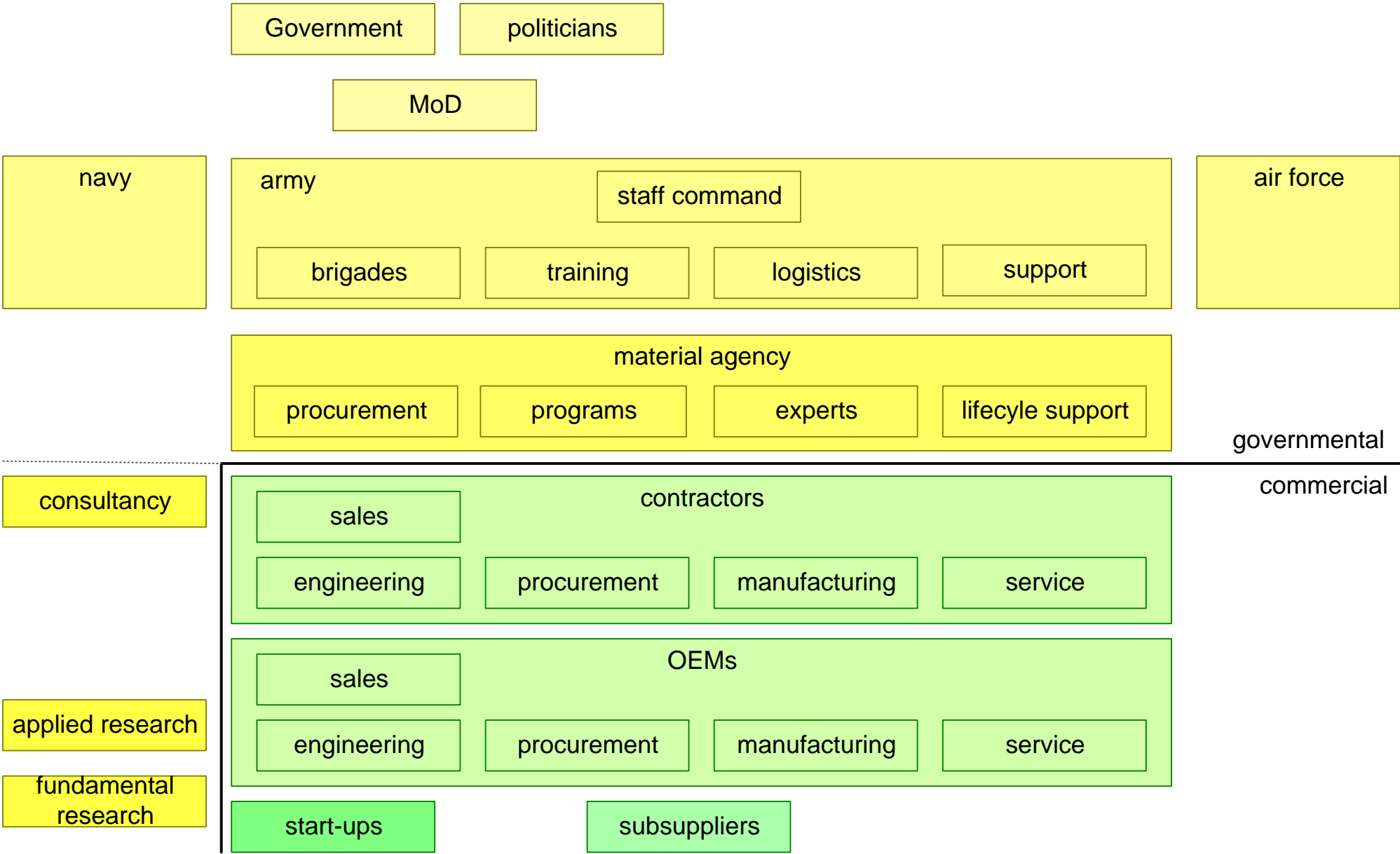

Example Solar Domain

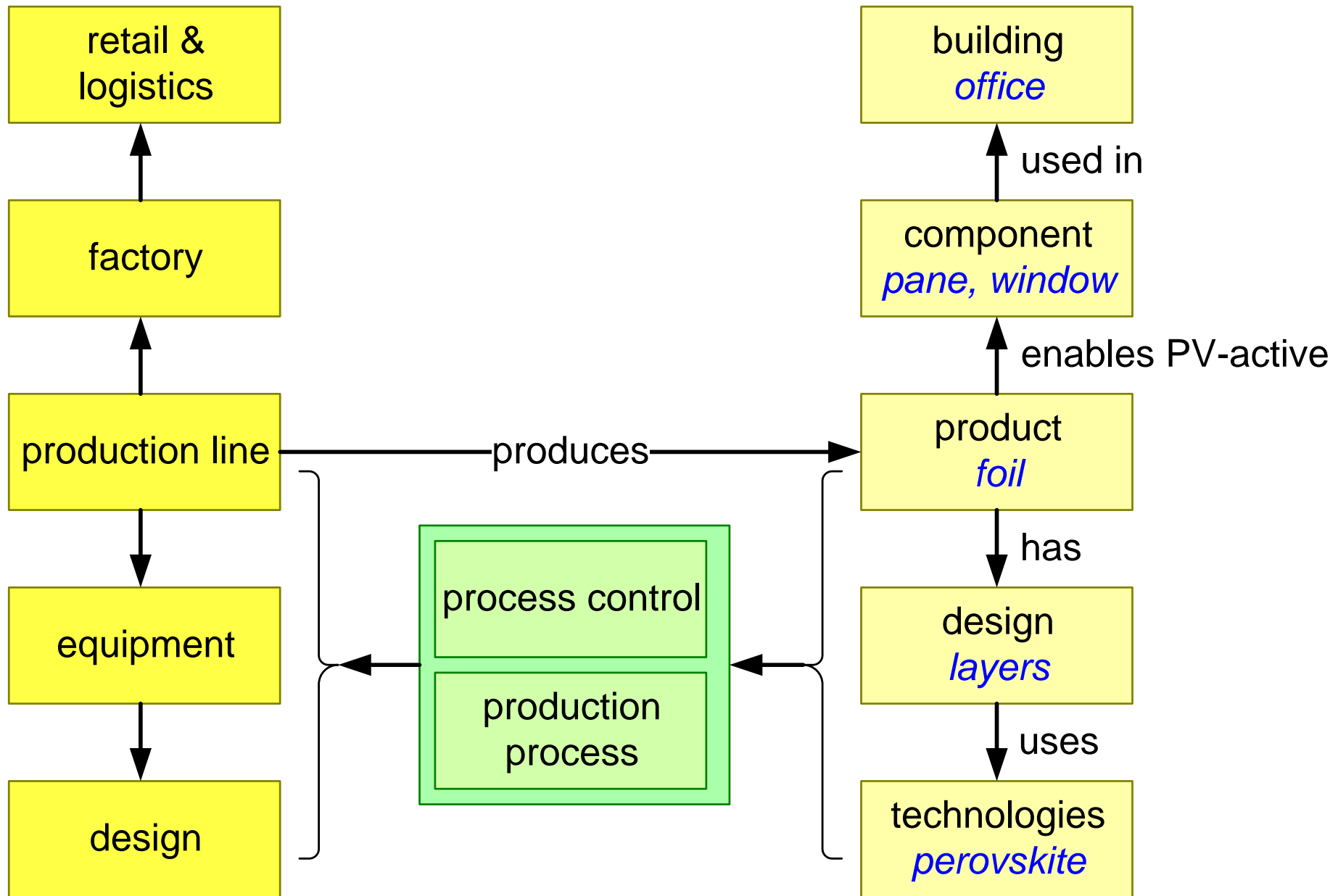

Layers in Solar example

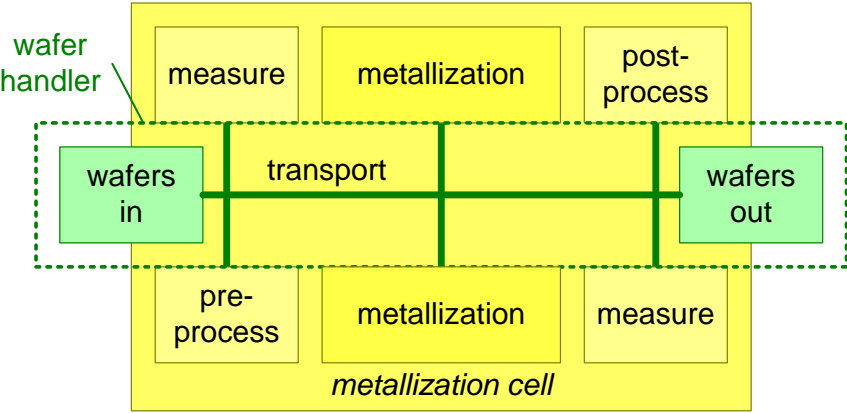
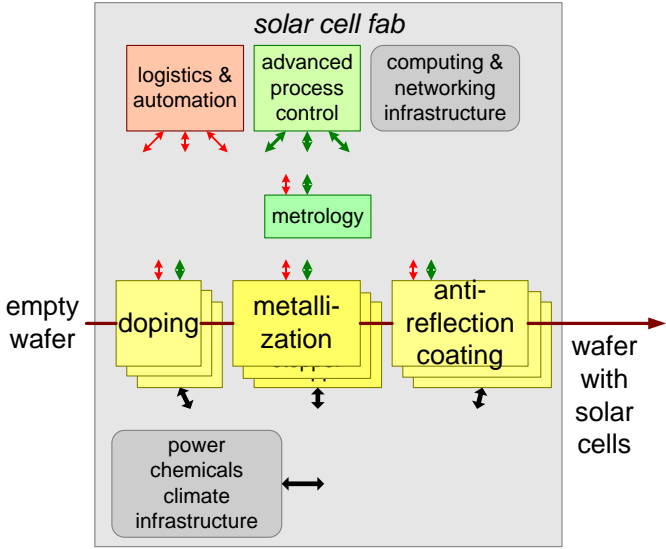
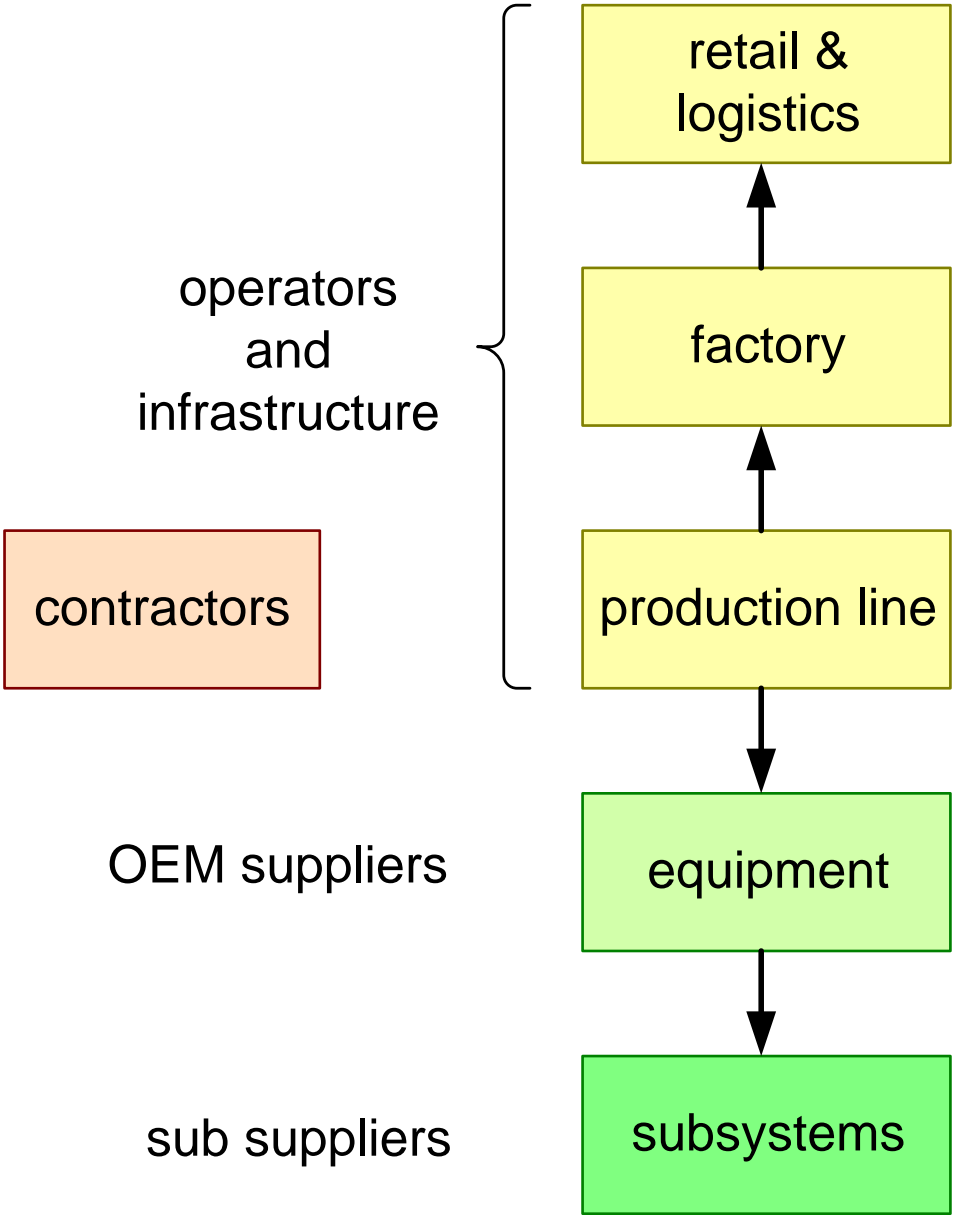

<https://www.gaudisite.nl/SolarCaseSESlides.pdf>

Example in Oil and Gas Offshore



operational

Equinor, Shell

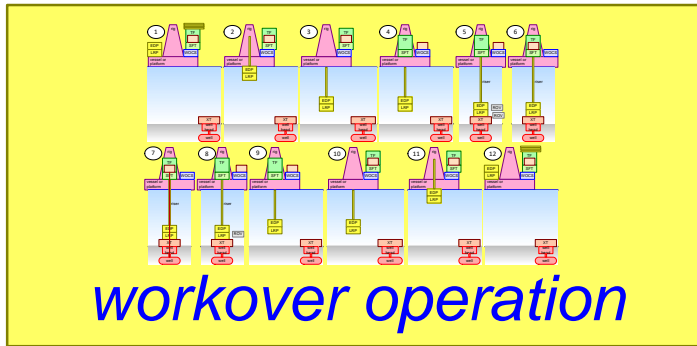

asset oriented

Equinor, Shell

TechnipFMC



project or product

TechnipFMC

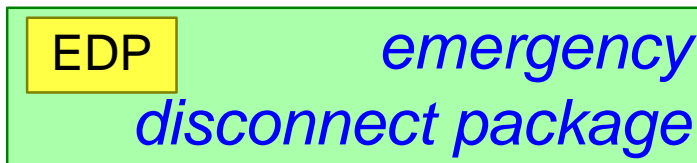

product

TechnipFMC

Part 2 Oil and Gas Subsea

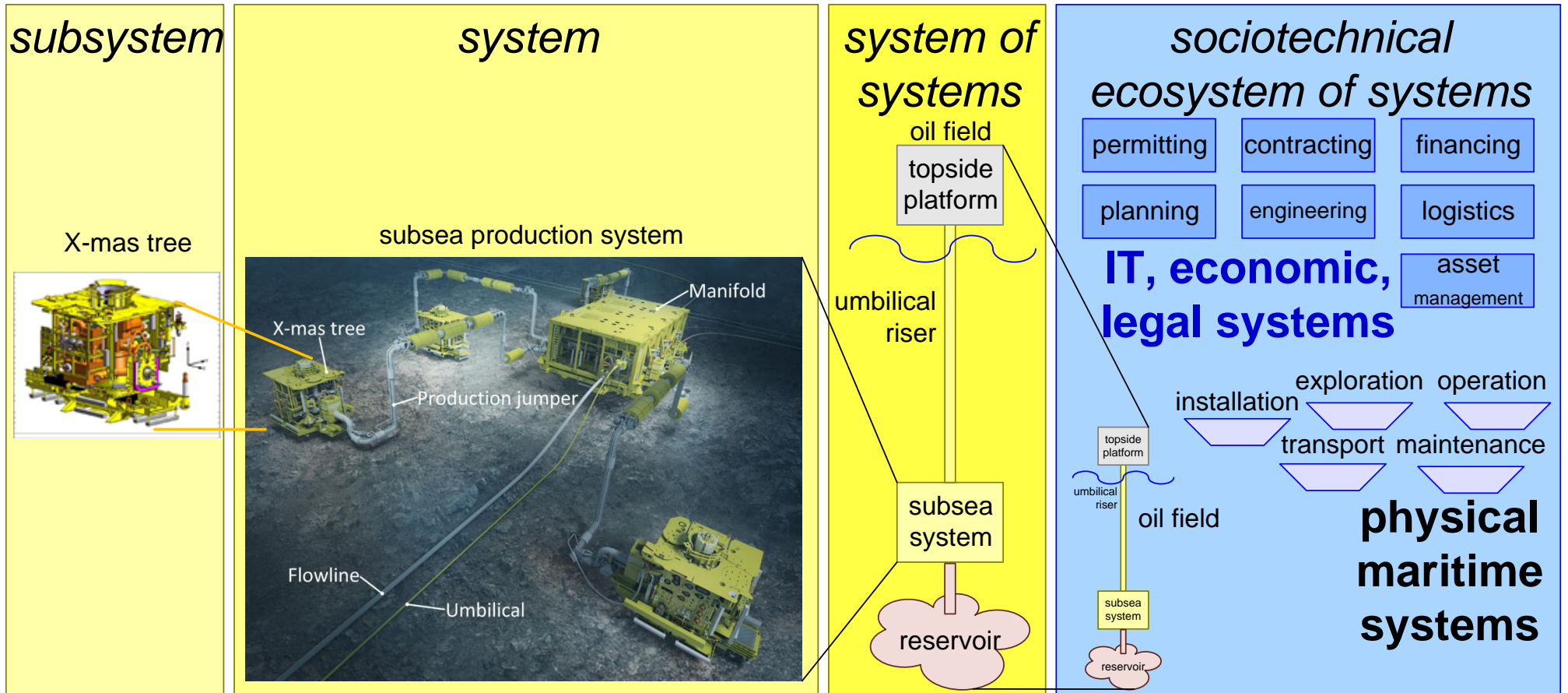

From: Managing Installation Tolerances through System Modeling and Tolerance Budgeting, INCOSE 2016, Hennager et al https://gaudisite.nl/INCOSE2016_HenangerEtAl_Tolerances.pdf

The Electric Power Ecosystem

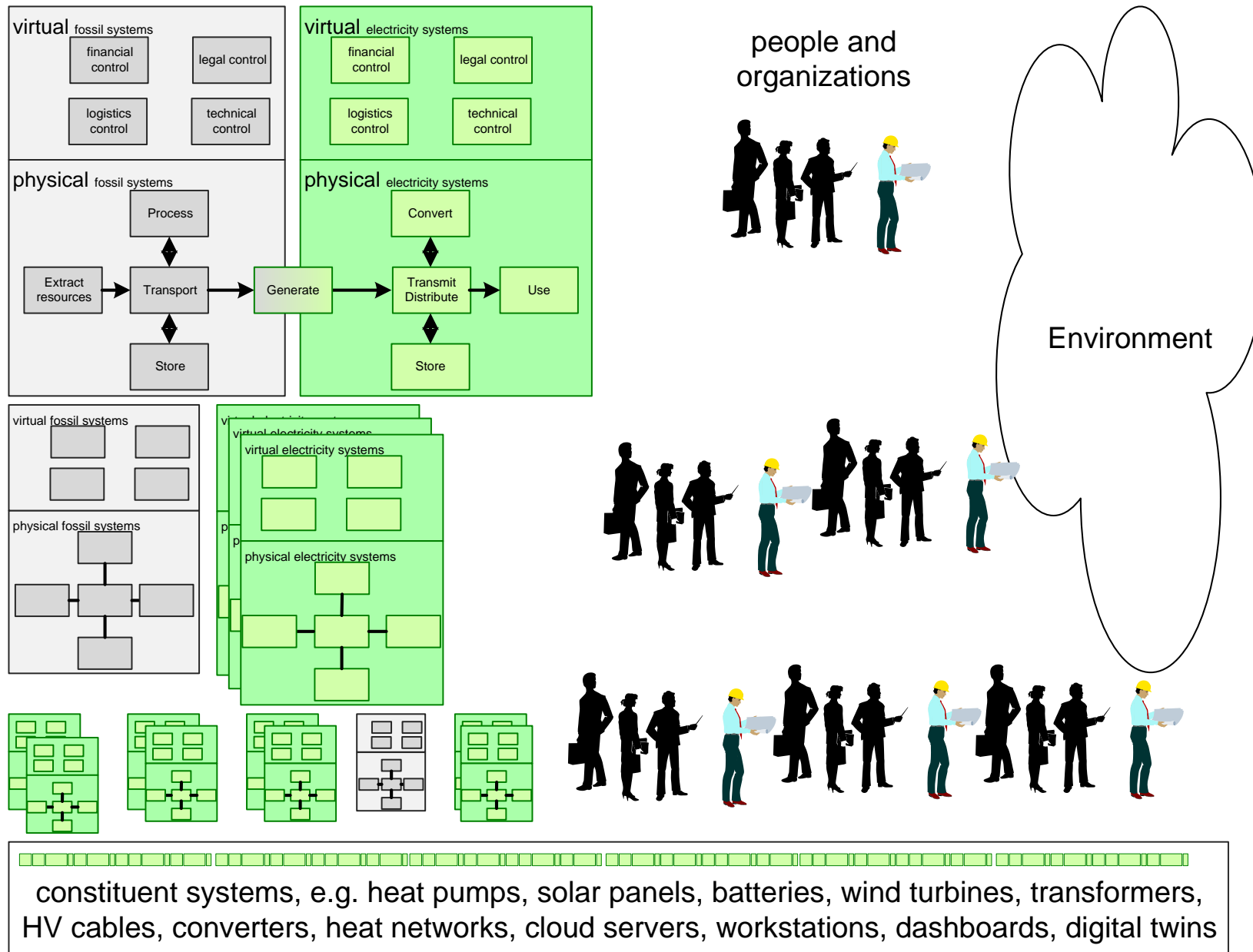

Example in Semiconductor Industry

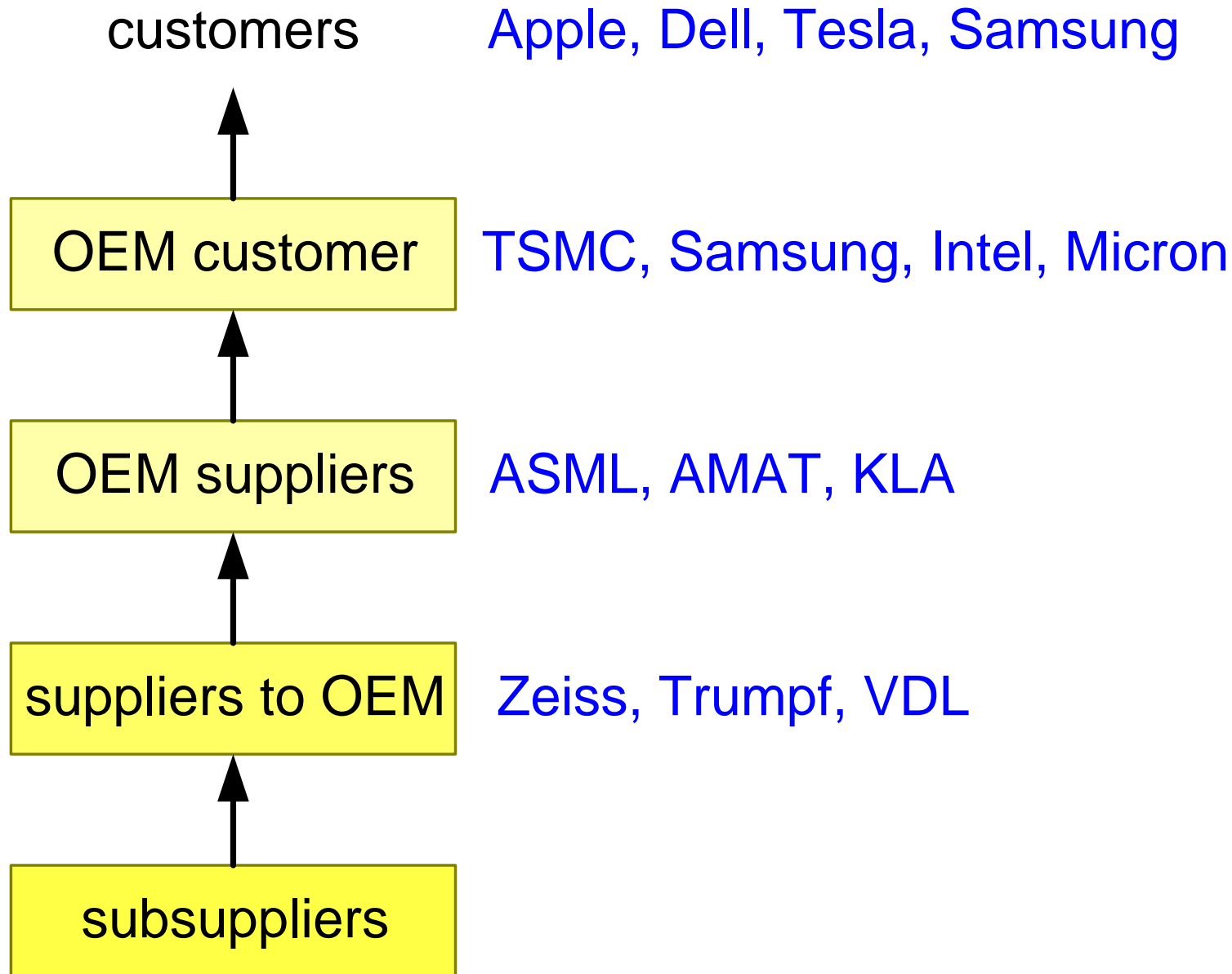

Inter-Enterprise

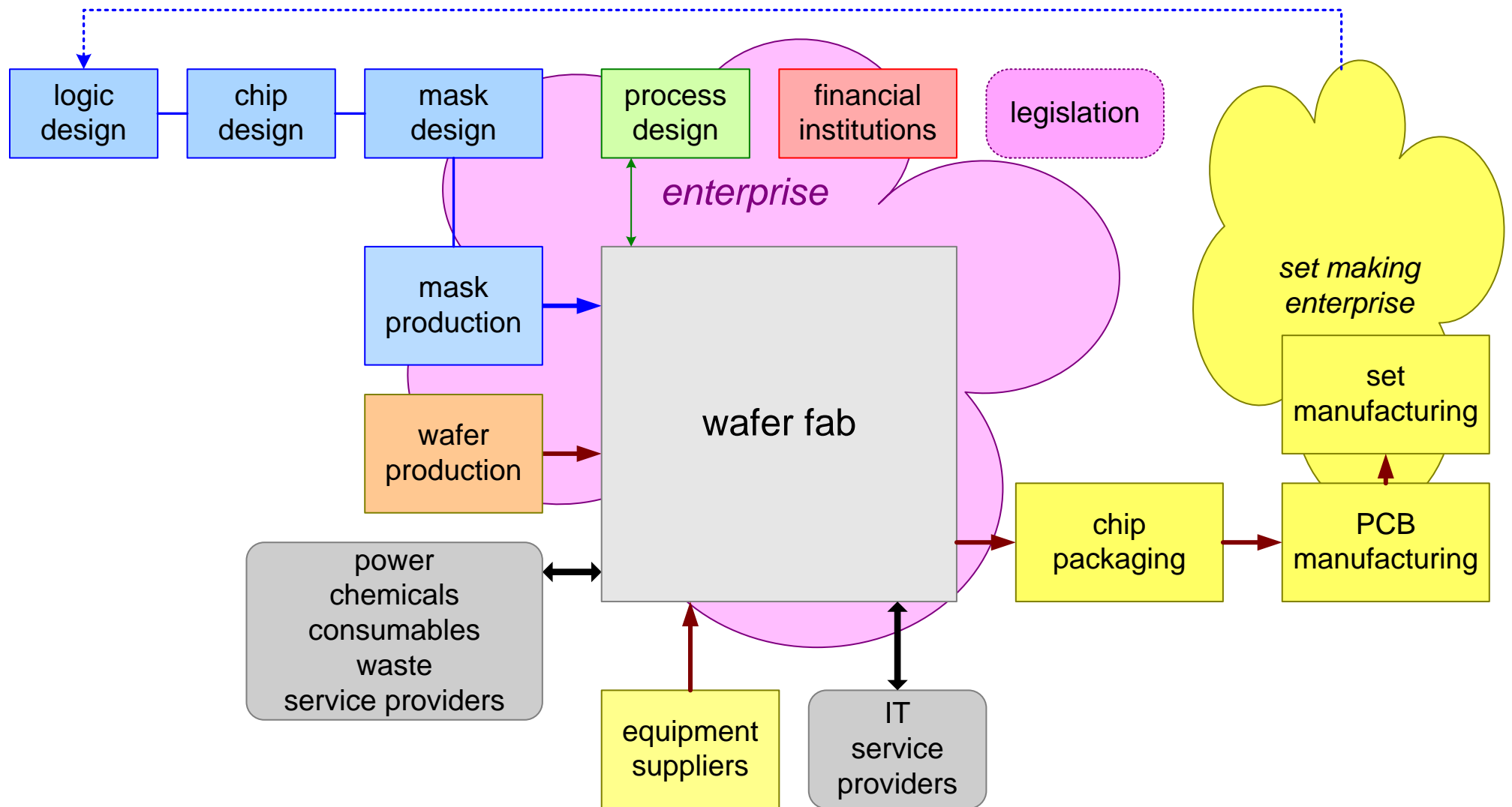

End-to-End Value-Chain

